



Merchandising



Communication



Instore Theater











The easy to install paper and electro labelling solution!

EASYFIX: THE SITOUR MERCHANDISING PATENTED ATTACHMENT SYSTEM

Two versions are available:

- > **Paper profile** (height: 39 mm; various lengths available; white or clear)
- > **Electro labelling rail** (for Pricer labels; various lengths available; clear)

Easy to install

- > **On shelves with 25 mm spacing:**
 - insert directly on the rail without need for any additional parts (patented by Sitour)
- > **On clips:**
 - for Tegometal, Double wire, Cefla, Kider KS, Fresh Bonnet Neve and Fresh Linde shelves

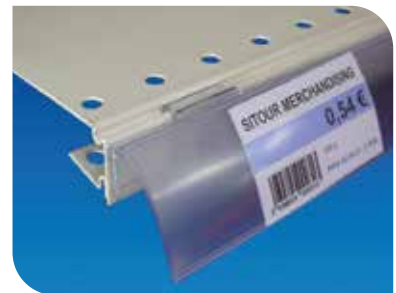
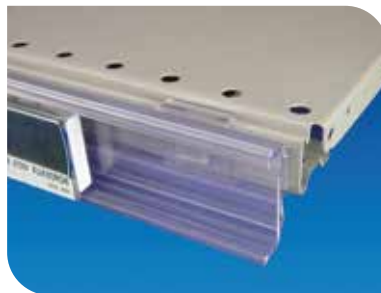

Suits to all types of food areas!



Modular

> Communication (paper and electro version)

- 31 mm decorative strips
- Shark feet, e-pop clips
- Shelf talkers, Coupon holders



> Hinged cover: easy to install (electro version)

- Decorative
- Hyper clear
- Remains fitted on the labelling rail when opened

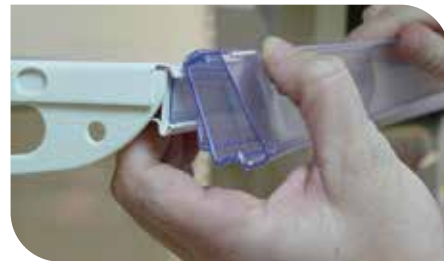

> Reading angle management via tilt spacers positioned on the back of the labelling rail (electro version)

- Spacer ref. 252 699
- Reading angle of 40°



Multi-purpose (electro version)

> Suitable for 3 generations of Pricer labels: Promoline, Continuum, Dot Matrix DM3370 Smart TAG

- Easy to insert
- Stable
- Easy to read (possible angle management)
- Protection (compatible cover)





... may we help you ?

THE RIGHT LABELLING SOLUTION EXISTS FOR EACH FIXTURE

P25 METAL FIXTURES *



- The Easyfix solution (Electro labelling rail or paper profile) can be fitted directly onto the shelf rail.
- The Freeline solution: 1 Freeline profile per P25 shelf type + individual paper or electro label holders.
- Individual P25 label holders (electro or paper).

TAGOMETALL FIXTURES



- The Easyfix solution (Electro labelling rail or paper profile) + the Temag Easyfix clips.
- The Freeline solution: 1 Tegometall Freeline profile + individual paper or electro label holders.
- Extruded paper Tegometall label holder profiles, can be clipped directly onto the shelf rail.

STRAIGHT EDGE FIXTURES



- The Freeline solution: 1 adhesive Freeline cap profile + individual paper or electro-Freeline label holders (P 20-21 or screw-on solution, contact us).
- The adhesive Electrorail solution, which can be applied directly as a shelf cap.

GLASS SHELF FIXTURES



- The Freeline solution: 1 pinch Freeline solution + individual paper or electro Freeline label holders.
- Pinch paper label holders.

WOODEN SHELF FIXTURES



- Folded or extruded adhesive paper label holder profiles.
- Pinch paper label holders.

DOUBLE WIRE SHELF FIXTURES



- The Wire shelf paper label holder profiles.
 - The Freeline: 1 Freeline profile + wire shelf clips + Freeline Easyfix solution (Electro labelling rail or paper or electro Freeline label holders (contact us).
- For single wire shelves and wire baskets, opt for the pinch solution.

PEG HOOKS

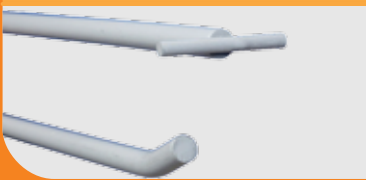

- Paper and electro peg hook label holders

On gondola

On peg-hook

In special area

... how does it work ?!

GLOBAL MERCHANDISING SOLUTION FOR SHELVES!
Created and Patented by Sitour Merchandising.

It is comprised of profiles that are compatible with most of the shelves on the market and of accessories that are fixed in the slots of the profiles.



Freeline adhesive cap

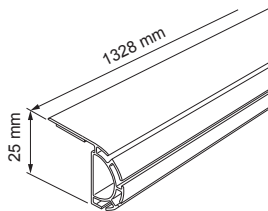
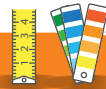

Universal. Ideal for shelves with regular front. Extruded profile designed to fit onto any type of shelf thanks to the adhesive tape fixed underneath its cap. Also available in 1000mm and 1245mm; other sizes available on demand. In PVC.



225 137	White - Length 1328 mm	Per 50
123 537	Cream 9001 - Length 1328 mm	Per 50
223 037	Light Grey 428C - Length 1328 mm	Per 50
224 937	Black 419C - Length 1328 mm	Per 50

Freeline adhesive cap with divider rail

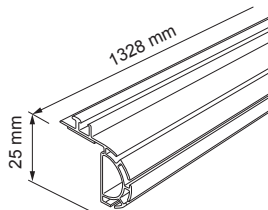
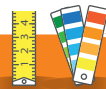

Universal. Ideal for shelves with regular front. Extruded profile designed to fit onto any type of shelf thanks to the adhesive tape fixed underneath its cap. Can receive dividers in its integrated front rail (add a back rail). Also available in 1245mm; other sizes available on demand. In PVC.



123 539	Cream 9001 with divider rail - Length 1328 mm	Per 50
----------------	---	--------

... did you know?

Segment your offer using the colour Freeline profiles!
Available in different colours, - Freeline cap available in specific colour starting from 2000 linear metres.
Contact us!



Freeline colour adhesive cap - Universal

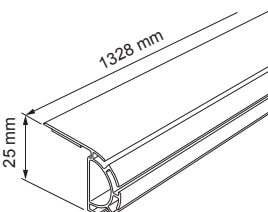

Universal. Ideal for shelves with regular front. Extruded profile that fits onto almost all of the shelves in the market thanks to the adhesive tape fixed underneath its cap. Segments your offer by colour. Also available in 1000mm; other sizes available on demand. In PVC.



223 337	Bright orange 1585C - Longueur 1328 mm	Per 50
225 237	Cherry Red 221 C - Length 1328 mm	Per 50
223 837	Olive Green 390 C - Length 1328 mm	Per 50
225 637	Fuchsia pink 241 C - Length 1328 mm	Per 50
225 037	Blue 299 C - Length 1328 mm	Per 50

Freeline for HERMES 25

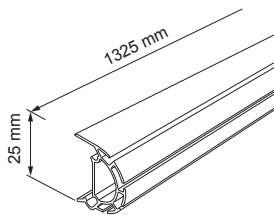
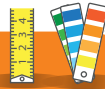

Adapted for HERMES 25mm shelves.
Extruded profile also available in 995mm and 1245mm; other sizes and colours available on demand.
In PVC.



123 521	Cream 9001 - Length 1325 mm	Per 50
223 021	Light Grey 428C- Length 1325 mm	Per 50
224 921	Black 419C - Length 1325 mm	Per 50

Freeline for HERMES 25 mm with divider rail

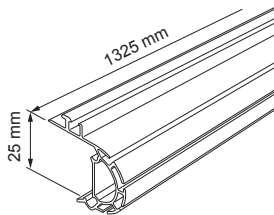
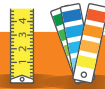

Adapted for HERMES 25mm shelves.
Can receive dividers in its integrated front rail (add a back rail). Extruded profile also available in 995mm and 1245mm; other sizes and colours available on demand.
In PVC.



123 527	Cream 9001 with divider rail - Length 1325 mm	Per 50
223 027	Light grey 428C with divider rail - Length 1325 mm	Per 50
224 927	Black 419C with divider rail - Length 1325 mm	Per 50

... did you know?



Boost your shelves with the Freeline in-store theatre accessories.

Discover the full range on page 103 to 110.



Freeline for ALSER/LAFORTEZZA 25

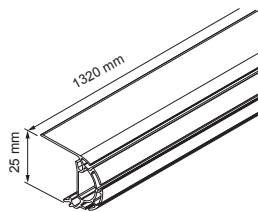
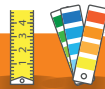

Adapted for ALSER and LA FORTEZZA 25 mm shelves.
also available in 990mm; other sizes and colours available on demand.
In PVC.



123 533	Cream 9001 - Length 1325 mm - 9001	Per 50
223 033	Light Grey 428C - Length 1320 mm	Per 50

Freeline for ALSER/LAFORTEZZA 25 with divider rail

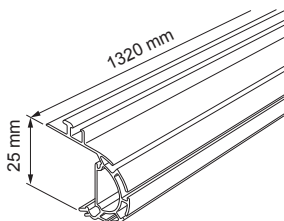
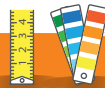

Adapted for ALSER and LA FORTEZZA 25mm shelves.
Can receive dividers in its integrated front rail (add a back rail). Extruded profile also available in 990mm; other sizes and colours available on demand.
In PVC.



123 535	Cream 9001 with divider rail - Length 1320 mm	Per 50
223 035	Light grey 428C with divider rail - Length 1320 mm	Per 50

Freeline for CEFLA/KIDER KS

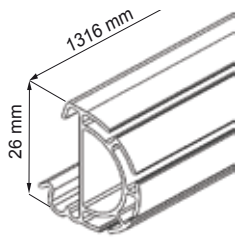
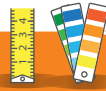

Adapted for CEFLA shelves. Extruded profile also available in 1000mm; other sizes and colours available on demand. In PVC.



123 573	Crème 9001 - Longueur 1316 mm	Per 50
225 373	Light Grey 428C- Length 1316 mm	Per 50
224 973	Black 419C - Length 1316 mm	Per 50

Freeline for CEFLA/KIDER KS with divider rail

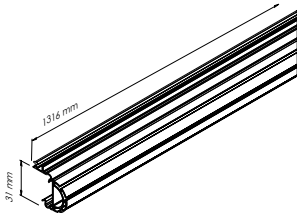
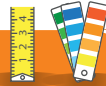

Adapted for CEFLA shelves. Can receive dividers in its integrated front rail (add a back rail). Extruded profile also available in 1000mm; other sizes and colours available on demand. In PVC.



223 081	Light grey 428C with divider rail - Length 1316 mm	Per 50
224 981	Black 419C with divider rail - Length 1316 mm	Per 50

Freeline for TEGOMETALL

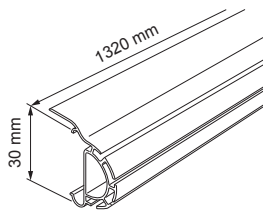

Adapted for TEGOMETALL shelves. Extruded profile also available in 988mm; other sizes available on demand. In PVC.



123 596	Cream 9001 - Length 1320 mm	Per 50
----------------	-----------------------------	--------

Freeline for TEGOMETALL with divider rail

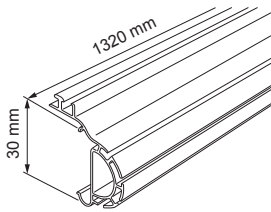

Adapted for TEGOMETALL shelves. Can receive dividers in its integrated front rail (add a back rail). Extruded profile also available in 988mm; other sizes available on demand. In PVC.



123 593	Cream 9001 with divider rail - Length 1320 mm	Per 50
123 592	Cream 9001 with divider rail - Length 988 mm	Per 50



Freeline wire basket

new

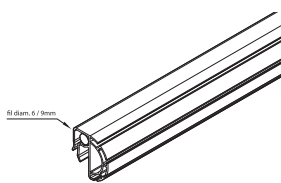

Adapted for baskets with a 6 to 9mm wire front. Extruded profile available in other sizes and colours on demand. In PVC.



123 554 Aluminium grey - Length 1285 mm

Per 50

Freeline for WANZL

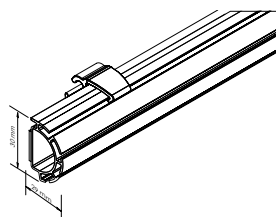

Adapted for Wanzl wire shelves. Extruded profile delivered with 3 adapters. Other sizes and colours available on demand In PVC.



123 576 Cream 9001 - Length 1328mm - (kit: Profile + 3 clips)

Per 50

252 309 Injected Wanzl Clip

Per 150

... did you know?



Find the Freeline range for chilled food areas on page 33. Discover our range of accessories supports of POS for Freeline profile on page 103 to 110.



Regular-front Freeline

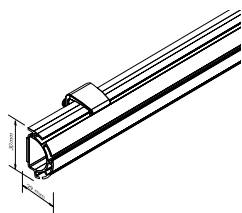

The clip allows to fix Freeline profiles onto shelves with regular front. Extruded profile delivered with 3 adapters. Other sizes and colours available on demand In PVC.



123 578 Cream 9001 - Length 1245mm - (kit: Profile + 3 clips)

Per 50

252 313 Injected screw clip

Per 150

Endcap for Freeline

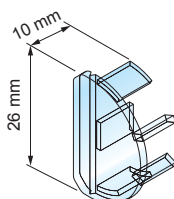

A perfect finish for your shelves. Clips onto both ends of Freeline. Clear. In PVC.

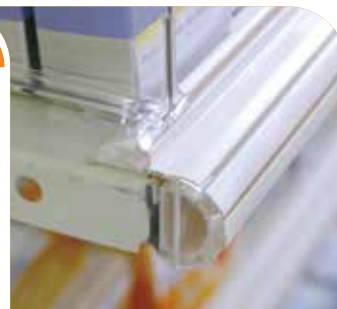

252 303 Endcap for Freeline

Per 100



... did you know?

1 label-holder, 2 reading angles.

Freeline patented fixing system allows to orientate label holders and guarantees optimal visibility of the price regardless of the height of the shelf!



Individual Pricer Freeline electronic label-holder

new

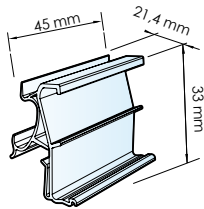

Designed to fix PRICER electronic labels on Freeline profiles. Compatible with Pricer Promoline, HS&HN, Continuum HCN, HCS, HCW, Dotmatrix DM3370 and Smart TAG labels. Extruded individual label-holder that inserts into the slots of Freeline profiles (reading angle management).
In PVC.



852 659	Clear - 33Ht x 45L mm - Promoline, Continuum, Dot Matrix and Smart TAG	Per 100
852 617	Clear - 24Ht x 98L mm - Continuum	Per 100
852 616	Clear - 42Ht x 90L mm - Dot Matrix	Per 100

Individual SES Freeline electronic label-holder

new

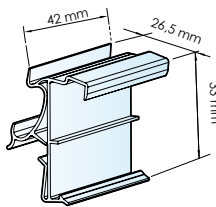

Designed to fix SES electronic labels on Freeline profiles. Compatible with different generations and lengths of SES labels. Extruded individual label-holder that inserts into the slots of Freeline profiles (reading angle management).
In PVC.



852 723	Clear - 33Ht x 42L mm - Stag, Gtag, S.	Per 100
----------------	--	---------

Dismantling tool

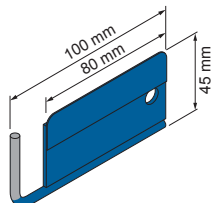

For removing electronic labels from the label-holder. Insert the flat part between the label and the label-holder and press by prying to remove the label.
Metal.



252 131	Blue - 45Ht x 100L mm	Per unit
----------------	-----------------------	----------

Electroline holder adapter on Freeline

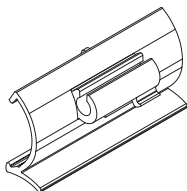

Designed to fix Electroline holders on Freeline profiles. Injected clip to be associated with an Electroline holder.
In PC.



252 301	Clear - For Freeline Profile	Per 100
----------------	------------------------------	---------

... did you know?

Electroline holders are available for most electronic labels on the market. They benefit from integrated reading angle management and secure your labels. Find the entire Electroline range on page 17.



Freeline individual ticket strip

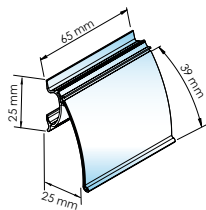

Designed to fix paper labels on Freeline profiles. Extruded individual label-holder that inserts into the slots of a Freeline profile (reading angle management).
In PVC.



852 729	Clear - 39Ht x 50L mm useful	Per 100
852 725	Clear - 39Ht x 65L mm useful	Per 100
852 727	Clear - 39Ht x 100L mm useful	Per 100

... did you know?



Freeline extruded paper label holders are available in different heights and lengths on request.
Contact us!



Freeline shelf booster

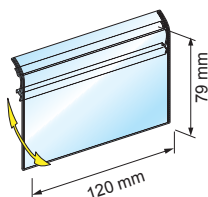

Increases your communication space on the shelves, close to the products. Clips into the Freeline slots according to the needed reading angle.
Visual is introduced from the rear.
In PVC.



852 612	Clear - 79Ht x 120L mm useful	Per 100
852 607	Clear - 79Ht x 150L mm useful	Per 100
852 609	Clear - 79Ht x 210L mm useful	Per 100
852 611	Clear - 79Ht x 300L mm useful	Per 100

OPTIMISE YOUR COMMUNICATION WITH THE DOUBLE EXPOSURE!

CONSULT US

Optimise the impact of your communications with the double exposure, both as facing and perpendicular to the shelf! Entrust us with creation and/or manufacture of your communication supports (information, POS...)! Request an estimate.



... how does it work ?!

R

A simple and flexible solution quick to install!

Created and patented by Sitour Merchandising. It is comprised of a labelling profile (electronic labelling rail or paper labelling profile) that is inserted directly into the C slot of fixtures with 25mm spacing (Hermès 25, Alser/Lafortezza 25...). Thanks to its range of adapters, can be used with other fixtures in the market (Cefla/kider KS, Tegometall, Linde & Bonnet Neve in the chilled food area).



Pricer Easyfix Label Rail



new

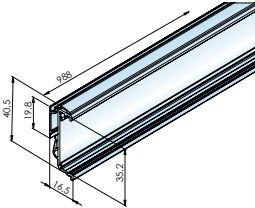

Designed to be fixed directly onto 25mm spacing shelves (Hermès 25, Alser 25 et Kider 25). Compatible with Pricer Promoline, HS&HN, Continuum HCN, HCS, HCW, Dotmatrix DM3370 and Smart TAG labels. Extruded label rail available in other lengths and colours on demand. In PVC.



252 713	Clear - Length 988 mm	per 50
252 714	Clear - Length 1240 mm	per 50
252 715	Clear - Length 1318 mm	per 50
252 743	Black - Length 1240 mm	per 50
252 741	Black - Length 1318 mm	per 50

... did you know?

R

Fix the Easyfix label rail in the shelves with 25mm spacing without any additional clips! Rear tab of the label rail to be inserted directly into the hollow front (C slot) of the shelf (insert the top of the label then the bottom of the label by moving across the length).



Cover for Pricer Easyfix label rail



new

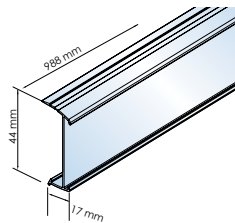

For protecting electronic labels from impacts. Perfectly clear hinged cover that clips to the top of the Pricer label rail. Opens while still remaining attached to the label rail. Available in several lengths. In PVC.



252 717	Clear - Length 988 mm	per 50
252 718	Clear - Length 1240 mm	per 50
252 719	Clear - Length 1318 mm	per 50

Electag Infomil Easyfix Label Rail



new

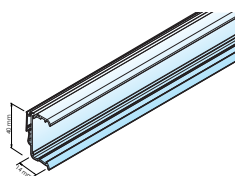

Designed to be fixed directly onto 25mm spacing shelves (Hermès 25, Alser 25 et Kider 25). Compatible with Electag Infomil labels. Extruded label rail available in other lengths and colours on demand. Cover available on demand. In PVC.



252 586	Clear - Length 988 mm	per 50
252 584	Clear - Length 1240 mm	per 50
252 582	Clear - Length 1318 mm	per 50

... did you know?



Adapt the Easyfix label rail to any type of fixture thanks to the various injected adapters. Adapters to be fixed onto the shelf (4 of which 2 at the ends and 2 at the centre) then the rear tab of the label rail to be inserted into the pinch of each adapter.



Easyfix adapter for other shelves

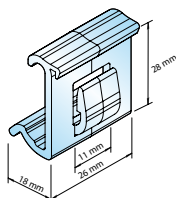
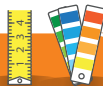

252 319 Clear - For Cefla & KiderKS shelves

Designed to adapt the Easyfix label rail to the fronts of Tegometall, Cefla and KiderKS shelves. We recommend 4 adapters per shelf. Injected adapter. In PC.



Per 200

Dismantling tool

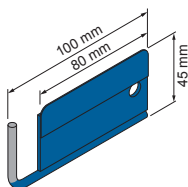

252 131 Blue - 45Ht x 100L mm

For removing electronic labels from the label-holder. Insert the flat part between the label and the label-holder and press by prying to remove the label. Metal



Per unit

... did you know?



The Easyfix label rail comes in an adhesive version, ideal for fixtures with a regular front. Available in different lengths. Contact us!



Adjustable spacer for label rail

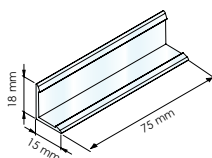

252 699 Clear - Length 75mm (2 angles)

Design to manage the angle of label rails. Provides for two reading angles. Inserts into the rear of the label rail, between the label profile and the front of the shelf. Extruded spacer. In PVC.



Per 50

... did you know?



Segment and boost your offer! Discover the Electro label rail in-store theatre accessories. To be fixed directly on the label rail or on the label rail cover on page 103 à 110.



... how does it work ?!



OPTIMISED PRICER LABELLING SOLUTION FOR TEGOMETALL SHELVES

Fixed directly onto the front of Tegometall shelves without any additional tools or parts!

Can be angled in 2 positions so you can choose the desired direction according to the height of your shelf (2 angles available) for optimized price reading!



Tego 2 positions Pricer label rail



new

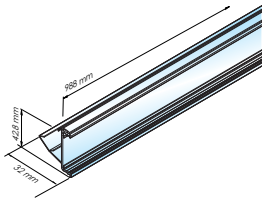

Designed to be fixed directly to the front of Tegometall shelves. The label can be angled in 2 positions (integrated function). Compatible with Pricer Promoline, HS&HN, Continuum HCN, HCS, HCW, Dotmatrix DM3370 and Smart TAG labels. Extruded label rail available in other lengths and colours on demand. In PVC.



252 735	Clear - Length 988 mm	Per 50
252 737	Clear - Length 1240 mm	Per 50
252 739	Clear - Length 1318 mm	Per 50

Decorative strip

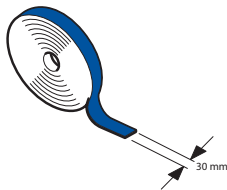

Designed to segment the offer. To insert in electronic rails. Other colours available on request. In PVC.



151 199	Blue - 30 mm Ht x 100 m Lg	Per unit
151 207	Cherry - 30 mm Ht x 100 m Lg	Per unit
151 205	Yellow - 30 mm Ht x 100 m Lg	Per unit
151 209	Green - 30 mm Ht x 100 m Lg	Per unit
151 225	Orange - 30 mm Ht x 100 m Lg	Per unit

SEGMENT YOUR OFFER!

CONSULT US

Segment your offer using these decorative strips to be inserted at the rear of the label rail.

Several colours available. Specific colours on demand starting from 4000 linear metres. Contact us!



... how does it work ?!

Universal electronic labelling solution!

A versatile solution that adapts to most fixtures (with adhesive tape or screws) and which accepts most of the electronic labels on the market.

A solution for in-store theatre that provides perfect visibility for your labels.



Electrorail

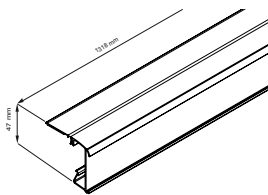

Universal. Designed to fit onto any type of shelf thanks to the adhesive tape fixed underneath its cap. Extruded label rail is compatible with most of the electronic labels on the market. Also available in 998mm and 1240mm; other sizes and colours available on demand.

In PVC.



252 655	Clear - Length 1318 mm	Per 50
252 667	Cream 9001 - Length 1318 mm	Per 50
252 679	Black 419C - Length 1318 mm	Per 50
252 673	Light Brown 7039 C - Length 1318 mm	Per 50

Electrorail V2

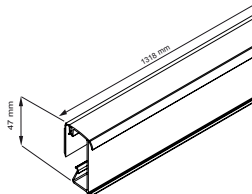

Universal. Ideal for regular fronts. Designed to be attached with adhesive tape to the front of the shelf. Extruded label rail is compatible with most of the electronic labels on the market. Other sizes and colours available on demand.

In PVC.



252 668	Cream 9001 - Length 1318 mm	Per 50
----------------	-----------------------------	--------

... did you know?



Segment and boost your offer! Discover the Electro label rail in-store theatre accessories, to be fixed directly on the label rail or on the label rail cover on page 103 - 110. Segment your offer using these decorative strips to be inserted at the rear of the label rail.

Several colours available.



Adjustable spacer for label rail

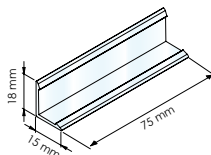

Design to manage the angle of label rails. Provides for two reading angles.

Inserts into the rear of the label rail, between the label profile and the front of the shelf. Extruded spacer.

In PVC.



252 699	Clear - Length 75 mm (2 angles)	Per 50
----------------	---------------------------------	--------

... did you know?

R

Protects your shelves, labelling profile and electronic labels from impacts (trolleys...) at the base of fixtures thanks to Springer!



Metal Springer

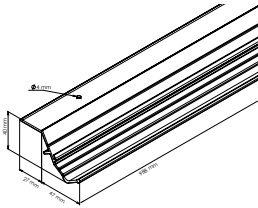

Designed to protect your shelves, labelling profile and electronic labels from impacts at the base of fixtures. Screws into the base of the fixture. To be associated with an Easyfix or Electrorail label rail. Metal.



252 709	Grey - Length 988 mm	Per 10
252 711	Grey - Length 1318 mm	Per 10

Springer PVC

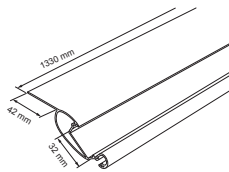

Designed to protect your shelves, labelling profile and electronic labels from impacts at the base of fixtures. Allow electronic labels to be inserted directly. Associate with a springer cover for optimum protection for labels. In PVC.



252 571	Cream 9001 - Length 1330 mm - PRICER	Per 10
252 573	Cream 9001 divider rail - Length 1330 mm - PRICER	Per 10
252 578	Cream 9001 - Length 1330 mm - NCR/SES	Per 10
252 580	Cream 9001 divider rail - Length 1330 mm - NCR/SES	Per 10

Springer PVC Cover

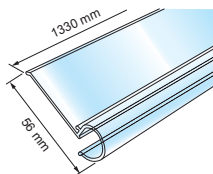

Designed to protect your electronic labels from impacts at the base of fixtures. Fits onto all Springers. In PVC.



252 615	Transparent - Longueur 1330 mm	Per 10
----------------	--------------------------------	--------

Dismantling tool

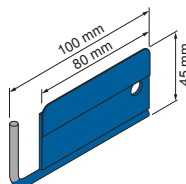

For removing electronic labels from the label-holder. Insert the flat part between the label and the label-holder and press by prying to remove the label. Metal.



252 131	Blue - 45 Ht x 100 L mm	Per unit
----------------	-------------------------	----------

... how does it work ?!



A FLEXIBLE, SIMPLE & HANDY INDIVIDUAL ELECTRONIC LABELLING SOLUTION!

The individual label-holder is attached directly to the front of the shelf or with adhesive tape onto the smooth and flat wall under each product concerned.

1 product = 1 label-holder = 1 price!



PRICER P25 individual label-holder

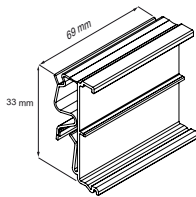

Designed to be fixed directly onto 25mm spacing shelves (Hermes 25, Alser 25 et Kider 25). Compatible with Pricer labels. Extruded individual label-holder available in different lengths on demand. In PVC.



852 731	Clear - 33 mm Ht x 47 L mm Promoline, Continuum, DM and SmartTAG	Per 100
852 733	Clear - 33 mm Ht x 69 L mm Promoline, Continuum, DM and SmartTAG	Per 100

PRICER adhesive individual label-holder

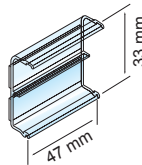

Universal. Extruded label-holder designed to be fixed on all types of straight supports (smooth and clean) thanks to its adhesive. Compatible with Pricer labels. Available in different lengths on demand. In PVC.



852 641	Clear - 33 mm Ht x 47 L mm - Promoline, Continuum, DM and SmartTAG	Per 100
852 643	Clear - 33 mm Ht x 69 L mm - Promoline, Continuum, DM and SmartTAG	Per 100
852 618	Clear - 47 mm Ht x 90 L mm - Promoline, Continuum, DM and SmartTAG	Per 100

SES adhesive individual label-holder

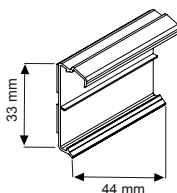

Universal. Extruded label-holder designed to be fixed on all types of straight supports (smooth and clean) thanks to its adhesive. Compatible with SES labels. Available in different lengths on demand. In PVC.



852 655	Clear - 33 mm Ht x 44 L mm - Stag, Gtag, S.	Per 100
852 657	Clear - 33 mm Ht x 60 L mm - Stag, Gtag, S.	Per 100

Versatile adhesive individual label-holder

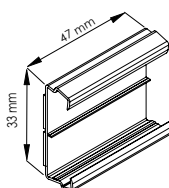

Universal. Extruded label-holder designed to be fixed on all types of straight supports (smooth and clean) thanks to its adhesive. Compatible with Pricer and SES labels. Available in different lengths on demand. In PVC.



852 620	Clear - 33 mm Ht x 47 L mm - Pricer & SES.	Per 100
----------------	--	---------

... how does it work ?!

R

UNIVERSAL & SECURE INDIVIDUAL ELECTRONIC LABELLING SOLUTION!

A versatile solution comprised of injected holders (covering most of the electronic labels on the market) and injected adapters (adapt to most of the fixtures on the market) to be assembled according to need.

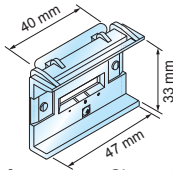
**PRICER Electroline Holder**

For PRICER electronic labels.
Directional spacer integrated into the rear of the holder, allows for 3 reading angles (-15°, 0°, 15°).
Injected holder to be associated with an Electroline adapter for fastening to a fixture.
In PC.



252 001	Clear - 33 mm Ht x 47 L mm - Promoline and Smart TAG	Per 100
252 033	Clear - 33 mm Ht x 47 L mm - Continuum	Per 100
252 003	Clear - 33 mm Ht x 69 L mm - Continuum & DM and Smart TAG	Per 100

... did you know?

R

Electroline holders are 1- highly resistant: injected PC. 2- secure: can only be removed with a special tool (anti-theft system). 3- directional, equipped with an integrated spacer allowing to move the label according to 3 angles (-15°, 0°, 15°) and a hinge system allows the customer to grasp a product easily. 4- Universal: compatible with most PRICER, SES, NCR and TAGGY electronic labels.

**SES Electroline Holder**

new

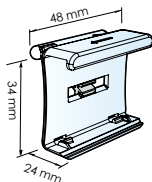

For SES electronic labels.
Directional spacer integrated into the rear of the holder, allows for 3 reading angles (-15°, 0°, 15°).
Injected holder to be associated with an Electroline adapter for fastening to a fixture.
In PC.

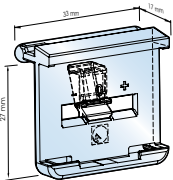

252 039	Clear - 34 mm Ht x 48 mm SES	Per 100
----------------	------------------------------	---------

NCR Electroline Holder

For NCR electronic labels.
Directional spacer integrated into the rear of the holder, allows for 3 reading angles (-15°, 0°, 15°).
Injected holder to be associated with an Electroline adapter for fastening to a fixture.
In PC.

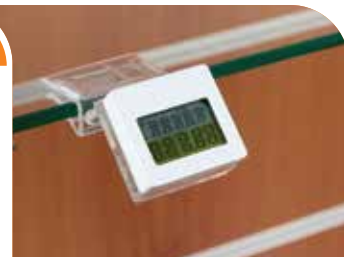

252 037	Clear - 27 mm Ht x 33 L mm - NCR	Per 100
252 021	Clear - 35 mm Ht x 60 L mm - NCR	Per 100

COMMUNICATE ON YOUR ELECTRONIC LABEL HOLDERS!**CONSULT US**

Optimise the impact of your promotions by dressing up your Electroline holders! Insert your POS and product information between the label and the holder. Entrust us with creation and/or manufacture of your communication supports (information, POS...) !



Electroline holder front shelf adapter 25 mm

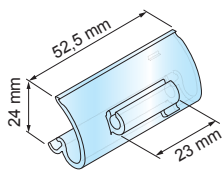

Designed to fix Electroline holders on fixtures with 25mm spacing. Injected clip to be associated with an Electroline holder. In PC.



- 252 101** Clear - HERMES 25, ALSER 25
- 252 125** Clear - Kider 25

Per 100
Per 100

Electroline holder front shelf adapter 37 mm

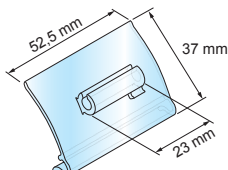

Designed to fix Electroline holders on fixtures with 37mm spacing. Injected clip to be associated with an Electroline holder. In PC.



- 252 107** Clear - HERMES 37 mm

Per 100

Electroline holder front wire shelf adapter

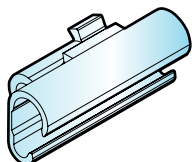

Designed to fix Electroline holders on fixtures with a wire front. Injected clip to be associated with an Electroline holder. In PC.



- 252 115** Clear - WANZL

Per 100

Electroline holder front straight shelf adapter

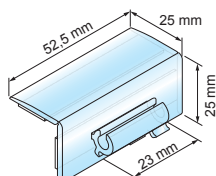

Designed to fix Electroline holders on fixtures with a regular front. Adhesive. Injected clip to be associated with an Electroline holder. In PC.



- 252 113** Clear - regular front

Per 100

... did you know?



Electroline adapters are 1- highly resistant: injected PC. 2- secure: can only be removed with a special tool (anti-theft system). 3- universal: compatible with most HERMES, METAL, ALSER fixtures, wire shelves, coolers, peg-hooks and Freeline.

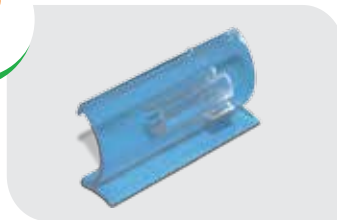

Dismantling tool

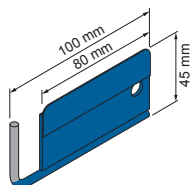

For removing electronic labels from the label-holder. Insert the flat part between the label and the label-holder and press by prying to remove the label. Metal.



- 252 131** Bleu - Hauteur 45 mm x Longueur 100 mm

Per unit

... how does it work ?!

A SIMPLE AND FLEXIBLE LABELLING SOLUTION THAT IS QUICK TO INSTAL!

Created and patented by Sitour Merchandising. It is comprised of a labelling profile (electronic labelling rail or paper labelling profile) that is inserted directly into the C slot of fixtures with 25mm spacing (Hermès 25, Alser/Lafortezza 25...). Thanks to its range of adapters, can be used with other fixtures in the market (Cefla/kider KS, Tegometall, Linde & Bonnet Neve in the chilled food area).

**Easyfix paper label-holder profile**

new

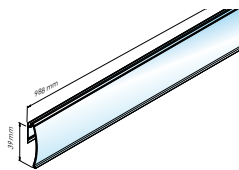

Designed to be fixed directly onto 25mm spacing shelves (Hermès 25, Alser 25 et Kider 25). For paper labels 39mm high. Extruded profile available in different lengths on demand. In PVC.

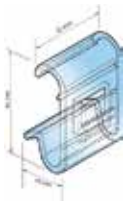

642 403	Clear - 39 mm Ht x 988 L mm useful	Per 50
642 405	Clear - 39 mm Ht x 1318 L mm useful	Per 50
642 413	White - 39 mm Ht x 988 L mm useful	Per 50
642 415	White - 39 mm Ht x 1318 L mm useful	Per 50

Easyfix adapter for other shelves

Designed to adapt the Easyfix paper labelling profile to the fronts of Tegometall, Cefla and KiderKS shelves. We recommend 4 adapters per shelf. Injected adapter. In PC.



252 315	Clear - Tegometall Shelf	Per 200
252 319	Clear - Cefla & KiderKS shelves	Per 200

... did you know?

Segment and boost your offer! Discover the in-store theatre accessories for paper profiles to be fixed directly to the label-holder on page... Segment your offer using these decorative strips to be inserted at the rear of the label rail. Specific colours on demand starting from 4000 linear metres. Contact us!

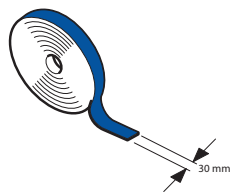
Bande de décoration

Designed to segment the offer. Inserts into the paper labelling profiles with a useful height of 39mm. Other colours available on request. In PVC.



151 099	Blue - 39 mm Ht x 100 m Lg	Per unit
151 115	Cherry - 39 mm Ht x 100 m Lg	Per unit
151 105	Yellow - 39 mm Ht x 100 m Lg	Per unit
151 109	Green - 39 mm Ht x 100 m Lg	Per unit
151 107	Orange - 39 mm Ht x 100 m Lg	Per unit

CEFLA-KIDER KS extruded ticket strip

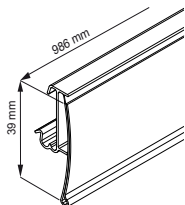

Designed to be fixed directly to the front of CEFLA and KIDERKS shelves. For paper labels with a useful height of 39mm. Extruded profile available in different lengths on demand. In PVC.



642 305	Clear - 39 mm Ht x 986 L mm useful	Per 100
642 307	Clear - 39 mm Ht x 1316 L mm useful	Per 50

PET TEGOMETALL extruded ticket strip

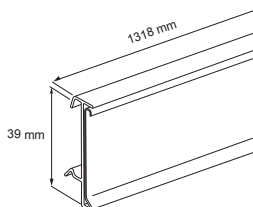

Designed to be fixed directly to the front of TEGOMETALL shelves. For paper labels of different heights. Extruded profile available in different lengths on demand. In PET.



642 555	White - 29 mm Ht x 1318 L mm useful	Per 50
642 553	White - 39 mm Ht x 1318 L mm useful	Per 50
642 557	White - 51 mm Ht x 1318 L mm useful	Per 50

PET TEGOMETALL 2-position extruded ticket strip

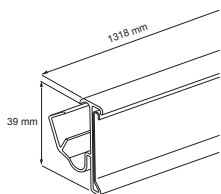

Designed to be fixed directly to the front of TEGOMETALL shelves. Two angles possible (2-notch rear tab). For paper labels with a useful height of 39mm. Extruded profile available in different lengths on demand. In PET.



642 558	White - 39 mm Ht x 1318 L mm useful	Per 50
----------------	-------------------------------------	--------

TEGOMETALL 2-position extruded ticket strip

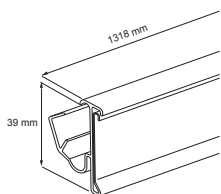

Designed to be fixed directly to the front of TEGOMETALL shelves. Two angles possible (2-notch rear tab). For paper labels of different heights. Extruded profile available in 988mm; other lengths available on demand. In PVC.



642 018	White - 39 mm Ht x 1318 L mm useful	Per 50
642 019	White - 51 mm Ht x 1318 L mm useful	Per 50
642 031	White - 59 mm Ht x 1318 L mm useful	Per 50

Extruded ticket strip, angled

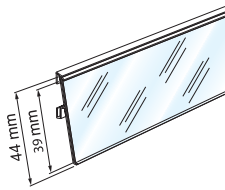

Designed to be fixed directly on the front of HERMES METAL or BONNET NEVE shelves where the front is perforated or provided with pins. Used with metal adapter 751 101. For paper labels 39mm high. Extruded profile available in different lengths on demand. In PVC.



642 087	White - 39 mm Ht x 999 L mm useful	Per 50
642 091	White - 39 mm Ht x 1325 L mm useful	Per 50
751 101	Metal adapter (4 or 5 according to Lg)	Per 250

Wire front extruded ticket strip

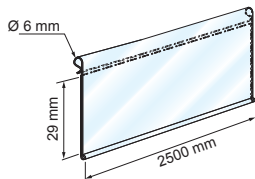

Designed to be fixed directly to the front of wire shelves. Extruded profile available in different lengths on demand. In PVC.

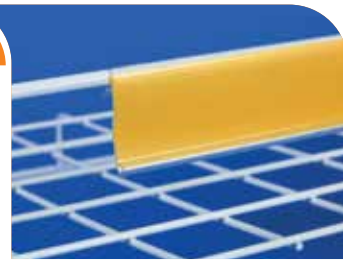

251 230	Clear - 29 mm Ht x 2500 L mm useful	Per 50
251 238	Clear - 39 mm Ht x 2500 L mm useful	Per 50

Front Wanzl extruded ticket strip

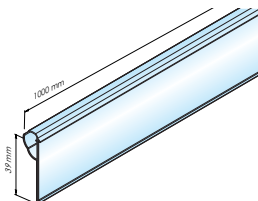

Designed to be fixed directly to the front of double wire Wanzl shelves. Extruded profile for paper labels with a useful height of 39 mm. Other colours available on request. In PVC.



642 230	Clear - 39 mm Ht x 988 L mm useful	Per 50
----------------	------------------------------------	--------

Wire basket pinch extruded ticket strip

new

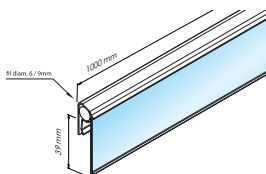

Designed to be fixed directly to the front of wire baskets. Extruded profile for paper labels with a useful height of 39mm. Other colours available on request. In PVC.



642 220	White - 39 mm Ht x 988 L mm useful	Per 50
----------------	------------------------------------	--------

Pinch profile for wire basket

new

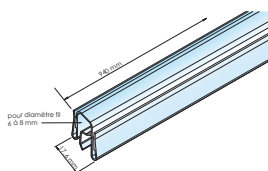

Designed to pinch a paper or electronic labelling profile and as such fix it to the wire basket. Available in different lengths. To be associated with an Easyfix paper (page 31) or Pricer electronic (page 23) profile



252 747	Clear background - Length 940 mm - with a pinch - to complete with an Easyfix label holder profile	Per 50
----------------	--	--------

Wanzl is registered trademark of Wanzl.

... how does it work ?!

R

UNIVERSAL PAPER LABELLING SOLUTION!

Flat and provided with a power adhesive, adapts to most flat, smooth and clean supports!

Extruded adhesive paper label-holders are very resistant and cannot be deformed. Folded adhesive paper label-holders are ultra clear and flat for optimum readability.

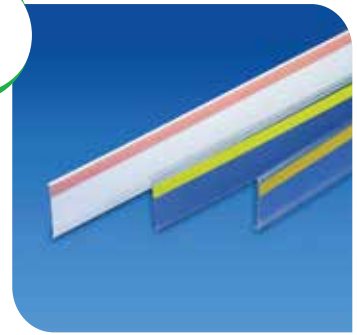

Extruded adhesive ticket strip

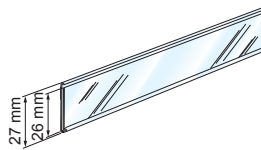

Universal. Ideal for regular fronts. Designed to be attached with adhesive tape directly to any flat, smooth and clean surface. For paper labels of different heights. Extruded profile available in 995mm. Other lengths available on request. In PVC.



641 013	Clear - 26 Ht x 1325 L mm useful	Per 50
641 015	Clear - 29 Ht x 1325 L mm useful	Per 50
641 017	Clear - 39 Ht x 1325 L mm useful	Per 50
641 019	Clear - 51 Ht x 1325 L mm useful	Per 50

PET extruded adhesive ticket strip

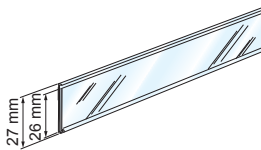

Universal. Ideal for regular fronts. Designed to be attached with adhesive tape directly to any flat, smooth and clean surface. Extruded profile with a frontside return to protect the labels. For paper labels of different heights. Other lengths available on request. In PET.



642 521	Clear - 26 Ht x 1325 L mm useful	Per 50
642 523	Clear - 29 Ht x 1325 L mm useful	Per 50
642 525	Clear - 39 Ht x 1325 L mm useful	Per 50

Extruded adhesive ticket strip

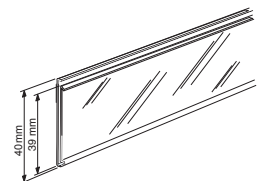

Universal. Ideal for regular fronts. Designed to be attached with adhesive tape directly to any flat, smooth and clean surface. Extruded profile for paper labels with a useful height of 39mm. Other colours available on request. In PVC.



642 037	White - 39 Ht x 100 L mm useful	Per 50
642 045	White - 39 Ht x 1325 mm useful	Per 50
642 051	Blue - 39 Ht x 1325 mm useful	Per 50

Hinged extruded ticket strip

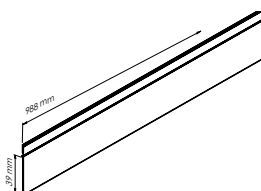

Designed to be attached with adhesive tape under another paper profile in order to increase the communication surface or to create a second level of labelling on the front of the shelf. White background extruded profile for paper labels of a height of 39mm with a hinge and adhesive. Other colours available on request. In PVC.



641 111	White - Length 988 mm - adhesive hinge	Per 50
----------------	--	--------

FOLDED TICKET STRIP

CONSULT US

Customised manufacturing! Folded paper label-holders are manufactured in our workshop.

We can produce your choice of an adhesive label-holder in length and height up to 160 mm.

With or without return, straight or angled.



Folded adhesive ticket strip

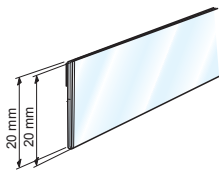

Universal. Ideal for regular fronts. Designed to be attached with adhesive tape directly to any flat, smooth and clean surface. Folded profile for paper labels of different heights. Available in lengths of 1330mm; other lengths and heights available on demand. Ultra clear & extra flat. In PVC antireflection.



137 120	Clear - 20 Ht AV - 20 Ht AR x 1000 L mm	Per 100
137 125	Clear - 26 Ht AV - 24 Ht AR x 1000 L mm	Per 100
137 131	Clear - 30 Ht AV - 20 Ht AR x 1000 L mm	Per 100
137 140	Clear - 40 Ht AV - 39 Ht AR x 1000 L mm	Per 100
137 150	Clear - 50 Ht AV - 30 Ht AR x 1000 L mm	Per 100
137 160	Clear - 60 Ht AV - 59 Ht AR x 1000 L mm	Per 100

Folded adhesive ticket strip - frontside return

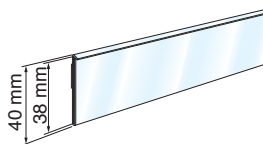

Universal. Ideal for regular fronts. Designed to be attached with adhesive tape directly to any flat, smooth and clean surface. Folded profile for paper labels of different heights. Available in lengths of 1000mm; other lengths and heights available on demand. The frontside return protects the price labels. Ultra clear & extra flat. In crystal or antireflection PVC.



641 025	Clear - 39 Ht x 1325 L mm Crystal	Per 50
641 061	Clear - 39 Ht x 1325 L mm useful - Antireflection	Per 50

Folded adhesive ticket strip - installation guide

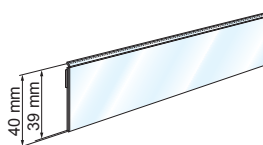

Universal. Ideal for regular fronts. Designed to be attached with adhesive tape directly to any flat, smooth and clean surface. Folded profile for paper labels of different heights. Available in lengths of 1000mm; other lengths and heights available on demand. The rear return installation guide ensures an quick and straight set-up. Ultra clear & extra flat. In PVC antireflection.



137 041	Clear - 39 Ht x 1325 L mm useful - Straight	Par 50
137 091	Clear - 39 Ht x 1325 L mm useful - Angled	Par 50

... did you know?

R

The range of individual paper label-holders is the flexible, simple and handy paper labelling solution. The individual paper label-holder is attached directly to the front of the shelf or with adhesive tape onto the smooth and flat wall under each product concerned.
1 product = 1 label-holder = 1 price!



Individual adhesive folded ticket-holder

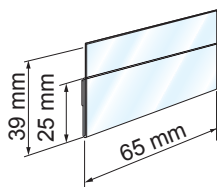

Universal. Ideal for regular fronts, cross-merchandising strips, promotional supports and cardboard displays. Designed to be attached with adhesive tape directly to any flat, smooth and clean surface. Folded, ultra clear & extra flat label-holder. Other sizes available on request.
In PVC.



137 033

Clear - 39 Ht x 65 L mm useful

Per 100

Individual P25 extruded ticket-holder

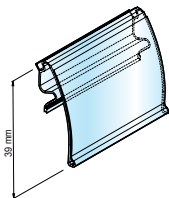

Designed to be fixed directly onto 25mm spacing shelves (Hermes 25, Alser 25 et Kider 25). For paper labels 39mm high. Extruded label-holder available in different lengths on demand.
In PVC.



642 100

Clear - 39 Ht x 65 L mm useful

Per 100

642 106

Clear - 39 Ht x 75 L mm useful

Per 100

642 107

Clear - 39 Ht x 80 L mm useful

Per 100

642 108

Clear - 39 Ht x 95 L mm useful

Per 100

642 101

Clear - 39 Ht x 100 L mm useful

Per 100

642 109

Clear - 39 Ht x 110 L mm useful

Per 100

White background individual P25 extruded ticket-holder

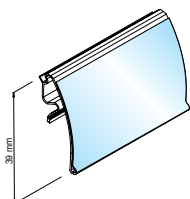

Designed to be fixed directly onto 25mm spacing shelves (Hermes 25, Alser 25 et Kider 25). For paper labels 39mm high. White background extruded label-holder available in different lengths on demand.
In PVC.



642 110

White - 39 Ht x 65 L mm

Per 100

642 111

White - 39 Ht x 100 L mm

Per 100

... how does it work ?!

R

UNIVERSAL & SECURE PEG-HOOK ELECTRONIC LABELLING SOLUTION!

A versatile solution comprised of injected holders (covering most of the electronic labels on the market) and injected adapters (adapt to different types of peg-hooks) to be assembled according to need.

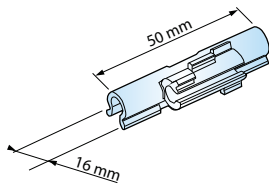
**Clip for axial and top hook Electroline holder**

Designed to fix Electroline holders on axial and top hooks. To be associated with an Electroline holder. In PC.

**252 153**

Clear - Axial and top hook

Per 100

... did you know?

R

1 ADAPTER FOR 2 TYPES OF PEG-HOOKS

For top merchandising hooks, you fix it on the top. For axial merchandising hooks, you fix it underneath. 1- Fix the clip on the label holder according to the type of peg-hook and slide the Electroline holder that corresponds to your label into the adapter. 2- Put the label into the holder. 3- Fix the label-holder on the hook.

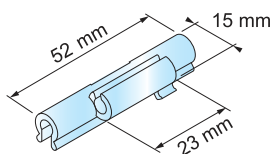
**Electroline holder adapter on low peg-hooks**

Designed to fix Electroline holders on low peg-hooks. To be associated with an Electroline holder. In PC.

**252 135**

Clear - Flat peg-hook

Per 100

... did you know?

R

Electroline holders are 1- highly resistant: injected PC. 2- secure: can only be removed with a special tool (anti-theft system). 3- directional, equipped with an integrated spacer allowing to move the label according to 3 angles (-15°, 0°, 15°) and a hinge system allows the customer to grasp a product easily. 4- Universal: compatible with most PRICER, SES, NCR and TAGGY electronic labels. Find the entire range on page 17.



PRICER individual peg-hook label-holder

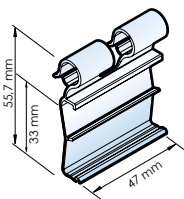

Designed to fix PRICER electronic labels on peg-hooks. Compatible with Pricer Promoline, HS&HN, Continuum HCN, HCS, HCW, Dotmatrix DM3370 and Smart TAG labels. Extruded individual label-holder. In PVC.



252 155

Clear - 33 Ht x 47 L mm - Promoline, Continuum, DotMatrix, Smart TAG

Per 100

SES individual peg-hook label-holder

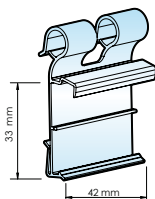

Designed to fix SES electronic labels on peg-hooks. Compatible with different generations and lengths of SES labels. Extruded individual label-holder. In PVC.



252 147

Clear - 33 Ht x 42 L mm - Stag, Gtag, S.

Per 100

Dismantling tool

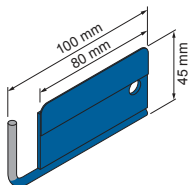

For removing electronic labels from the label-holder. Insert the flat part between the label and the label-holder and press by prying to remove the label. Metal.



252 131

Blue - 45 Ht x 100 L mm

Per unit

... did you know?

Communicate with your peg-hooks!
Discover in-store theatre solutions for peg-hook areas on page 107.



Rear access 8 mm notch ticket-holder

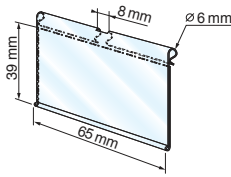

Designed to be fixed on 8mm max diameter peg-hooks. Extruded label-holder for paper labels of different heights. Rear access. In PVC.



- 137 006** Clear - 39 Ht x 65 L mm useful - diam 6 mm
- 137 007** Clear - 29 Ht x 60 L mm useful - diam 6 mm

Per 100
Per 100

Rear access 11 mm notch ticket-holder

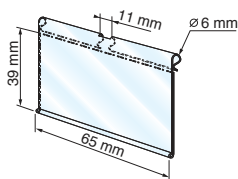

Designed to be fixed on 11mm max diameter peg-hooks. Extruded label-holder for paper labels of different heights. Rear access. In PVC.



- 251 105** Clear - 39 Ht x 65 L mm useful - diam 6 mm

Per 100

... did you know?



CAN BE CUSTOMISED TO FIT YOUR DIMENSIONS!

On request we will produce the peg-holder label-holder with the length of your choice!

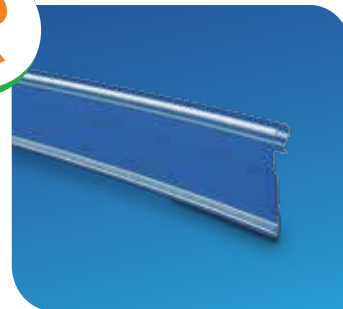

Front access 11 mm notch ticket-holder

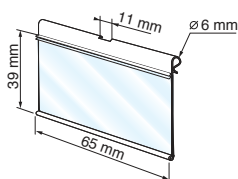

Designed to be fixed on 11mm max diameter peg-hooks. Extruded white background label-holder for paper labels of different heights. Front access. Compatible with several sizes of wire with a maximum diameter of 11 mm. PVC.



- 251 101** White - 39 Ht x 65 L mm useful - diam 6 mm
- 251 103** White - 39 Ht x 70 L mm useful - diam 6 mm

Par 100
Par 100

CUSTOMIZE YOUR PEG-HOOK LABEL HOLDER

CONSULT US

Increase the visibility of your brands and promotions by customizing your peg-hook label-holder! Entrust us with creation and/or manufacture of your customised label-holders (upper part printed in your colours)! Request an estimate.



Endcap for hook

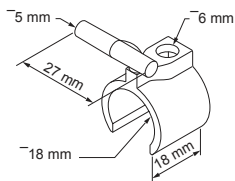

Designed for hanging paper label-holders. Attaches to 18mm diameter tubes. PVC.

137 011 White - diam 18 mm



Per 100

Pole endcap for tube

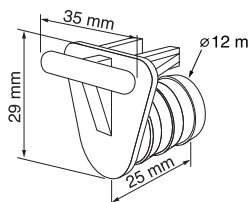

Designed for hanging paper label-holders. Inserts into 19mm diameter tubes. PVC.

137 004 White - diam 12mm - With locking

137 005 White - diam 12mm - Without locking



Per 100

Per 100

... did you know?

Communicate with your peg-hooks next to your label by adding communication on shark foot. Consult the peg-hook in-store theatre accessories on page 107.

R



Wire peg-hook hinged label-holder

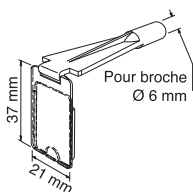

Designed to be fixed on 6mm diameter wire peg-hooks of paper labels in 37x21mm format. Gets through the blister pack. Hinged system. Injected. PVC.

251 017 White - 37 x 21 mm label - Wire diam 6 mm



Per 250

Double peg-hook paper label-holder

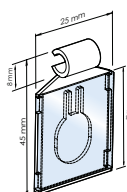

Designed to be fixed on double PVC peg-hooks of paper labels in 30x25mm format. Gets through the blister pack. Hinged system. Injected. PVC.

137 330 White - 30 x 25 mm label - double wire



Per 100

... how does it work ?!

R

THE ELEGANT POS AND PRICE DISPLAY SOLUTION!

Ideal for Beauty/Health areas. It allows prices to be displayed at the front of the shelf as well as highlighting promotional product offers.



Pinch Pureline profile



new

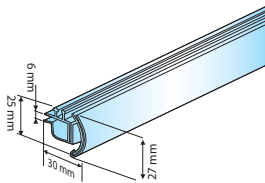

Fits onto glass shelves 6 to 10 mm thick. Extruded pinch profile. Comprised of a groove to receive communication supports. Available in different lengths and black and white on demand. PVC.

123 602 Clear - with pinch - Length 1000 mm



Per 25

Magnetic Pureline profile



new

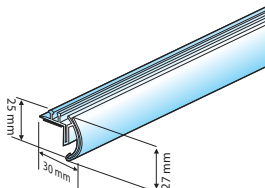

Adapted for metal shelves. Extruded profile with a magnetic base. Comprised of a groove to receive communication supports. Available in different lengths and black and white on demand. PVC.

123 604 Clear - magnetic - Length 1000 mm



Per 25

Adhesive Pureline profile



new

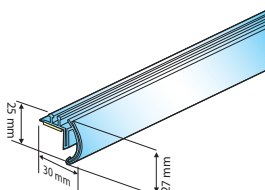

Adapted for all types of supports. Extruded profile with an adhesive base. Comprised of a groove to receive communication supports. Available in different lengths and black and white on demand. PVC.

123 606 Clear - adhesive - Length 1000 mm

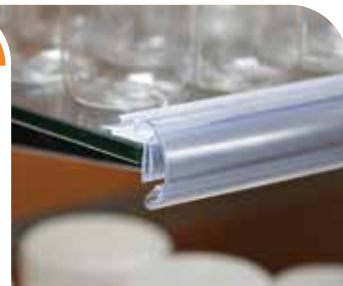

Per 25

... did you know?

R

Discover the entire range of merchandising accessories... Boost, leaflet dispenser, supports for promotional product offers, etc. It is fixed directly on the Pureline profile in order to be closer to the products. Contact us to test it!



Freeline for glass shelves

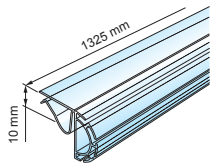

Fits onto glass shelves 6 to 10 mm thick. Extruded pinch profile available in different lengths on demand. PVC.



123 552 Clear - with pinch - Length 1325 mm

Per 50

... did you know?



1 label-holder, 2 reading angles.

Freeline patented fixing system allows to orientate label holders and guarantees optimal visibility of the price regardless of the height of the shelf!



Individual Pricer Freeline electronic label-holder

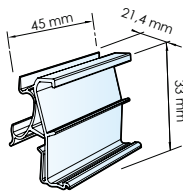

Designed to fix PRICER electronic labels on Freeline profiles. Compatible with Pricer Promoline, HS&HN, Continuum HCN, HCS, HCW, Dotmatrix DM3370 and Smart TAG labels. Extruded individual label-holder that inserts into the slots of Freeline profiles (reading angle management). PVC.



852 659 Clear - 33 Ht x 45 L mm - Promoline, Continuum, DotMatrix, Smart TAG

Per 100

852 617 Clear - 24 Ht x 98 L mm - Continuum

Per 100

852 616 Clear - 42 Ht x 90 L mm - Dot Matrix

Per 100

Individual SES Freeline electronic label-holder

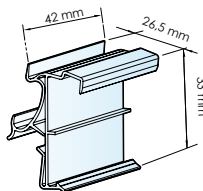

Designed to fix SES electronic labels on Freeline profiles. Compatible with different generations and lengths of SES labels. Extruded individual label-holder that inserts into the slots of Freeline profiles (reading angle management). PVC.



852 723 Clear - 33 Ht x 42 L mm - Stag, Gtag, S.

Per 100

Dismantling tool

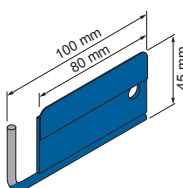

For removing electronic labels from the label-holder. Insert the flat part between the label and the label-holder and press by prying to remove the label. Metal.



252 131 Blue - 45 Ht x 100 L mm

Per unit

... did you know?



Find the range of Freeline in-store theatre accessories on page 103 - 110.



Electroline holder adapter on Freeline

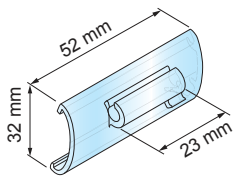

Designed to fix Electroline holders on Freeline profiles. Injected clip to be associated with an Electroline holder. In PC.



252 301

Clear - Freeline

Per 100

... did you know?



The electronic label holders are available for most of electronic labels. Thanks to a groove built into the casing, the electronic labels can be adjusted to 3 angles depending on the label location on the gondola. Very resistant, the holders and clips ensure a secure fixing of the electronic labels. Discover the Electroline range page 17.



Electroline holder glass shelf adapter

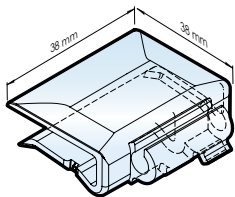

Designed to fix Electroline holders directly on glass shelves. Injected clip to be associated with an Electroline holder. Can be adapted to all Electroline holders. In PC.



252 129

Clear - 6 mm glass shelf

Per 100

252 130

Clear - 8 mm glass shelf

Per 100

252 132

Clear - 12 mm glass shelf

Per 100



Glass table pinch angled profile

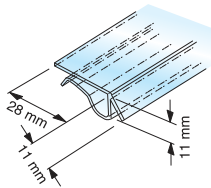

Designed to be fixed on 5 to 11 mm glass tables. Extruded pinch profile to associate with an adhesive label-holder profile at your choice of height. Available in different lengths on demand. PVC.

160 300 Clear - Length 2000 mm



Per 50

Adhesive folded paper label-holder profile frontside

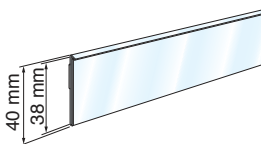

Universal. Ideal for regular fronts. Designed to be attached with adhesive tape directly to any flat, smooth and clean surface. Folded profile for paper labels of different heights. Available in lengths of 1000mm; other lengths and heights available on demand. The frontside return protects the price labels. Ultra clear & extra flat. In crystal or antireflection PVC.

641 025 Clear - 39 mm Ht useful x1325 mm Lg - Crystal

641 061 Clear - 39 mm Ht useful x1330 mm Lg - Antireflection



Per 50

Per 50

... did you know?

Customised manufacturing! Folded paper label-holders are manufactured in our workshop.

We can produce your choice of an adhesive label-holder in length and height up to 160 mm.

With or without return, straight or angled.

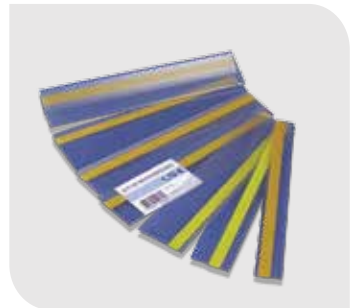

Reform Display can also be found on facebook

Visit our facebook account



Other dimensions available



Other colors available



New product



Takes part of the **AIR programme** (eco-responsible)

... how does it work ?!

R

GLOBAL MERCHANDISING

SOLUTION FOR SHELVES IN THE COOLED/COLD AREA!

This solution adapts to fixtures of the «cabinet», «shark» or «chest» type in cold as well as frozen areas! Associate adapters with your choice of Freeline profile!



Magali rail double wire front Freeline



Fits onto the double wire Bonnet Neve shelf fronts (or with Magali rail) and the KOXKA fixtures. Comprised of the 3 adapters and a Freeline extruded profile available in different colours and lengths on demand. PVC profile. PC adapters.



123 575	Cream 428C - Length 1245 mm - (kit: Profile + 3 clips)	Per 50
224 475	Black 419C - Length 1245 mm - (kit: Profile + 3 clips)	Per 50
223 075	Mouse grey 428C - Length 1245 mm - (kit: Profile + 3 clips)	Per 50
252 307	Clear - Double wire injected adapter	Per 200

... did you know?

R

Freeline, also for frozen!

Freeline MAGALI can also be installed on 2 or 3-wire shelves, frozen cabinet fixtures and Bonnet Névé shark cases.



Freeline Bonnet Névé



Adapted for the front of Linde Chief shelves. Comprised of 3 adapters and a Freeline extruded profile available in different colours and lengths on demand. PVC profile. PC adapters.



123 577	Cream 428C - Length 1245mm - (kit: Profile + 4 clips)	Per 50
224 477	Black 419C - Length 1245 mm - (kit: Profile + 4 clips)	Per 50
223 077	Grey 428C - Length 1245mm - (kit: Profile + 4 clips)	Per 50
252 305	Clear - Bonnet Névé injected adapter	Per 200

Freeline Linde Chief

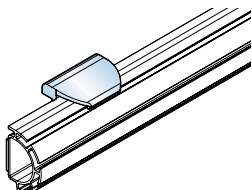

Adapted for the front of Linde Chief shelves. Comprised of 3 adapters and a Freeline extruded profile available in different colours and lengths on demand. PVC profile. PC adapters.



123 584	Cream 428C - Length 1245 mm	Per 50
223 084	Grey 428C - Length 1245 mm	Per 50
223 484	Black 419C - Length 1245 mm	Per 50
252 311	Clear - Linde Chief injected adapter	Per 200

... did you know?

R

Dress up the doors of your cabinet fixtures in chilled and cold areas by affixing your communication supports with «micro suction cup», the no-glue adhesive that leaves no marks on your glass. Easy to install, it can easily be used again. Trust us with your projects. Contact us!



SEGMENT YOUR OFFER!

CONSULT US

Use Freeline colours to segment your offer!
Compose your customised Freeline labelling kits by associating Freeline adapters with the profiles of your choice. Display your prices thanks to the range of Freeline paper or electronic label-holders and provide your shelves with in-store theatre thanks to the in-store theatre accessories of the Freeline range!



Freeline wire basket

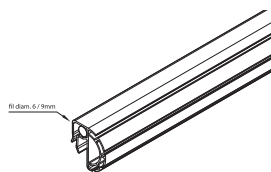
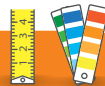

Adapted for baskets with a wire front circumference of 6 to 9mm.
Extruded profile available in other sizes and colours on demand.
PVC.



123 554 Aluminium grey - Length 1285 mm

Per 50

Freeline WANZL

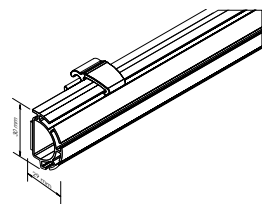
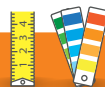

Adapted for Wanzl wire shelves. Extruded profile delivered with 3 adapters.
Other sizes and colours available on demand
PVC.

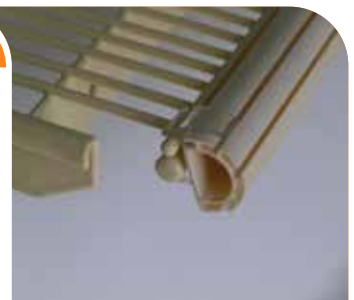

123 576 Cream 9001 - Length 1328mm - (kit: Profile + 3 clips)
252 309 Injected Wanzl Clip

Per 50
Per 150

Regular front Freeline

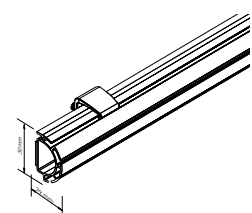

The clip allows to fix Freeline profiles onto shelves with regular front.
Extruded profile delivered with 3 adapters.
Other sizes and colours available on demand
PVC.



123 578 Cream 9001 - Length 1245 mm - (kit: Profile + 3 clips)
252 313 Clear - Injected Clipavis

Per 50
Per 150

Freeline Freezer pyramid

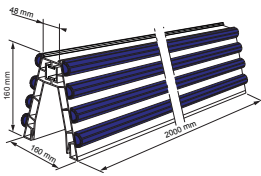

Designed to be fixed on the upper and central part of frozen food wells. Pyramid composed of 4 levels of Freeline blue labelling profiles on each side. Can be installed in a classic or aero way. PVC.



214 075

White with Freeline blue - 160 Ht x 1240 L mm

L'unité

... did you know?

R

Freeline Magali can also be adapted for 2 or 3 wires shelves in Bonnet Neve coolers!



Freeline Freezer pyramid extension

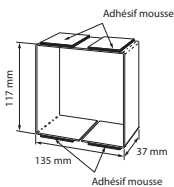

Elevates the freezer pyramid on certain relief fixtures. Adhesive. PVC.



177 107

White - 117 Ht x 135 L mm

Per 2

... did you know?

R

To display your promotional offers in the frozen section, use the hanger for freezer pyramids (ref. 841121)!

Contact us!



Freeline aero metal base for freezer pyramids

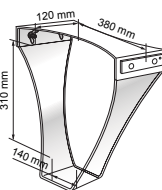

Ideal for wide frozen food wells. Brings the labelling closer to the edge of the frozen food well for better price visibility. Metal.



215 001

White - 130 Ht x 380 L mm

Per 2

Finish endcap for Freeline frozen pyramids

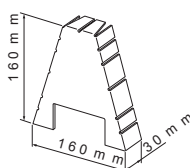

Designed to be fixed onto the ends of the frozen pyramid for a better finish. Available for pyramids in traditional version and for aero version pyramids.



177 103

White - 160 Ht x 160 L mm - traditional version

Per 2

177 113

White - 160 Ht x 58 L mm - aéro version

by 2 pairs

... how does it work ?!



UNIVERSAL & RESISTANT INDIVIDUAL ELECTRONIC LABELLING SOLUTION, IDEAL FOR CHILLED/COLD SECTIONS!

A versatile solution comprised of injected holders (covering most of the electronic labels on the market) and injected adapters (adapt to Magali et Bonnet Névé fixtures) to be assembled according to need.



Electroline holder adapter for chilled fixtures

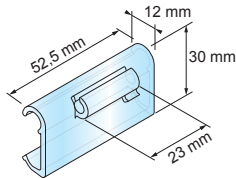

Designed to fix Electroline holders on Bonnet Névé and Magali fixtures. Injected clip to be associated with an Electroline holder. In PC.



- 252 109** Clear - Magali adapter
- 252 123** Clear - Bonnet Névé adapter

Per 100
Per 100

PRICER Electroline Holder

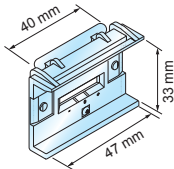

For PRICER electronic labels. Directional spacer integrated into the rear of the holder, allows for 3 reading angles (-15°, 0°, 15°). Injected holder to be associated with an Electroline adapter for fastening to a fixture. In PC.



- 252 001** Clear - 33 Ht x 47 L mm - Promoline and Smart TAG
- 252 033** Clear - 33 Ht x 47 L mm - Continuum
- 252 003** Clear - 33 Ht x 69 L mm - Continuum & DM and Smart TAG

Per 100
Per 100
Per 100

SES Electroline holder

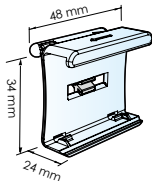

For SES electronic labels. Directional spacer integrated into the rear of the holder, allows for 3 reading angles (-15°, 0°, 15°). Injected holder to be associated with an Electroline adapter for fastening to a fixture. In PC.



- 252 039** Clear - 34 Ht x 48 SES

Per 100

Electag Infomil holder

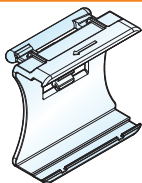

For Electag Infomil electronic labels. Directional spacer integrated into the rear of the holder, allows for 3 reading angles (-15°, 0°, 15°). Injected holder to be associated with an Electroline adapter for fastening to a fixture. In PC.

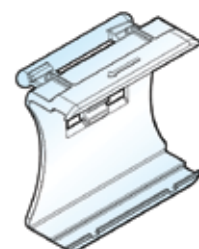

- 252 051** Small size
- 252 053** Large size

Per 100
Per 100

Dismantling tool

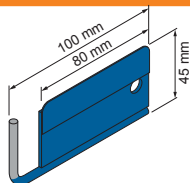

For removing electronic labels from the label-holder. Insert the flat part between the label and the label-holder and press by prying to remove the label. Metal.



- 252 131** Blue - 45 Ht x 100 L mm

Per 50

... how does it work ?!



A SIMPLE AND FLEXIBLE LABELLING SOLUTION THAT IS QUICK TO INSTALL!

Created and patented by Sitour Merchandising. It is comprised of an extruded labelling profile, rail for Pricer electronic labels or paper labelling profile. Thanks to its range of adapters, Easyfix can also be used for other fixtures in chilled and cold sections: Bonnet Névé, Magali and Linde Chief.



Easyfix adapter

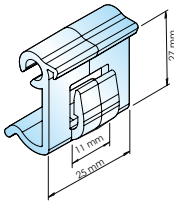

Fixes the Easyfix paper profile or rail onto the various shelves.
We recommend 4 adapters per shelf.



252 315	Magali Easyfix front rail adapter	Per 200
252 323	Bonnet Névé Easyfix adapter	Per 200
252 321	Linde Easyfix adapter	Per 200

Pricer Easyfix Label Rail

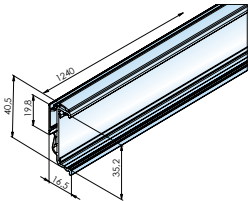

Designed to be fixed directly onto 25mm spacing shelves (Hermes 25, Alser 25 et Kider 25). Compatible with Pricer Promoline, HS&HN, Continuum HCN, HCS, HCW and Dotmatrix DM3370 labels.
Extruded label rail available in other lengths and colours on demand. PVC.



252 714	Clear - Length 1240 mm	Per 50
252 743	Black - Length 1240 mm	Per 50

... did you know?



Segment and boost your offer!

Discover the Electro label rail in-store theatre accessories. To be fixed directly on the label rail or on the label rail cover on page 113 - 110. Segment your offer using these decorative strips to be inserted at the rear of the label rail.

Several colours available.



Cover for Pricer Easyfix label rail

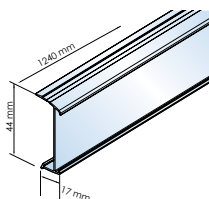

For protecting electronic labels from impacts. Perfectly clear hinged cover that clips to the top of the Pricer label rail. Opens while still remaining attached to the label rail.
Available in several lengths.
PVC.



252 718	Clear - Length 1240 mm	Per 50
----------------	------------------------	--------

Easyfix paper label-holder profile

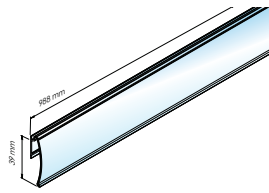

Designed to be fixed directly onto 25mm spacing shelves (Hermes 25, Alser 25 et Kider 25). For paper labels 39mm high. Extruded profile available in different lengths on demand. PVC.



- 642 404** Clear - 39 Ht x 1240 L mm useful
- 642 414** White - 39 Ht x 1240 L mm useful

Per 50
Per 50

... did you know?

Segment and boost your offer! Discover the in-store theatre accessories for paper profiles to be fixed directly to the label-holder on page 103 - 110. Segment your offer using these decorative strips to be inserted at the rear of the label rail.

R



Double wire angled profile with flap

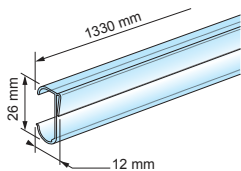

Fits onto double wire shelves. To be associated with an adhesive ticket strip. Different lengths available on demand. PVC.



- 641 101** Clear - Length 1330 mm

Per 100

... did you know?

Find the range of adhesive label-holder profiles on page 22.

R

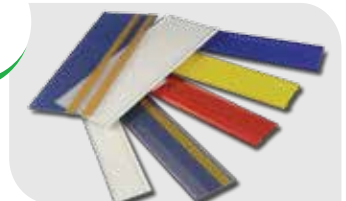

2-positions Label-holder profile

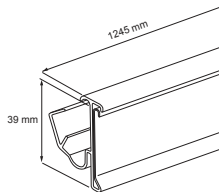

Designed to be fixed directly to the front of Linde Chief shelves. Two angles possible (2-notch rear tab). For paper labels with a useful height of 39mm. White background extruded profile available in different lengths on demand. PVC.



- 642 017** White - 39 Ht x 1245 mm useful

Per 50

Folded paper label holder profile for cold fixture

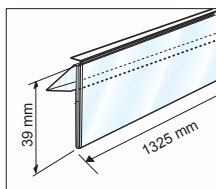

To insert into the slot of the the labelling rails of cold fixtures. Antireflection.



- 137 091** Clear - 39 Ht x 1325 L mm useful

Per 50

... did you know?



Ideal for traditional chilled counters (dairy, catering, butcher or seafood) that offer little space for communication, the Label First offers a flexible solution for price display.

Hyper-compact First label is 20% smaller and its digits are 10% larger than a traditional label with crown.

Label First is available in 2 sizes:

- The classic Label First with 5 crowns
- The Large label First with 6 crowns (that allows to communicate on 6 figures prices).

The face of the Label First is customizable and can be changed.



First label, black edition

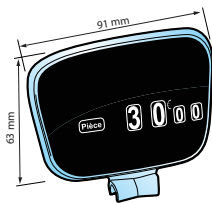

215 959 Black edition

For displaying prices in the traditional areas. 5 crowns for the display. Bi-conical connector allows the label to be angled. Suitable with a complete range of holders and bases. Extra visuals can be added on the back. Polypro.



Per 50

Colour First Label

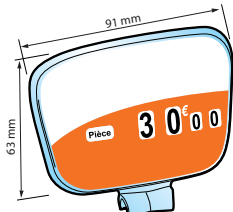

215 951 Orange

215 953 Red

215 955 Purple

215 957 Green

For displaying prices in the traditional areas. 5 crowns for the display. Bi-conical connector allows the label to be angled. Suitable with a complete range of holders and bases. Extra visuals can be added on the back. Polypro.



Per 50

Per 50

Per 50

Per 50

Etiquette First Vichy

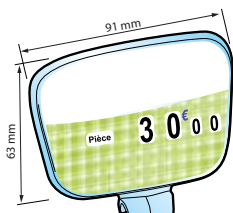

215 941 Yellow/white

215 943 Red/white

215 945 Pink/white

215 947 Green/white

For displaying prices in the traditional areas. 5 crowns for the display. Bi-conical connector allows the label to be angled. Suitable with a complete range of holders and bases. Extra visuals can be added on the back. Polypro.



Per 50

Per 50

Per 50

Per 50

... how does it work ?!



First XL!

Minimum size with maximum display for product information!

First XL's additional crown allows the fat % to be indicated. An ideal solution for dairy products!



First XL Label

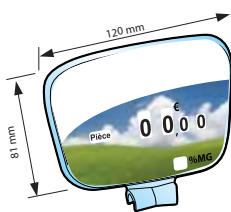

For displaying prices in the traditional areas. 6 crowns for the display. Displays the fat percentage. Bi-conical connector allows the label to be angled. Suitable with a wide range of holders and bases. Extra visuals can be added on the rear. Polypro



215 977

Fish face

Customised front face on request

Per 50

... how does it work ?!



First Label is also versatile!

First XL's 6th crown allows you to display prices up to 3 digits after the decimal, an ideal solution for your export process.



Fish price board

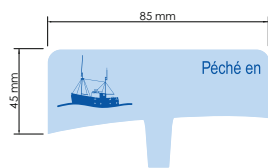

Designed to fit on the rear of First labels
Kit containing 210 fishing method boards
90 ex - Caught in
40 ex - Raised in
20 ex - Elaborated in
20 ex - Caught in fresh water in



215 995

Fish price board kit

215 997

PROMOTION VISUAL

215 999

NEW VISUAL

Kit

Kit with 50 copies

Kit with 50 copies

PROTHESE COMMUNICATION

CONSULT US

The communication and price board is made to be installed at the back of the label First.

Available on demand.



... did you know?



Our supports have a SITOUR patented biconical connector. Specially designed for managing 3 reading angles (-25°, 0° and 25°) with First labels.

So your prices can always be read in all of your stall configurations.



Low base holder for label First

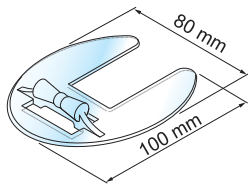

Designed to attach First labels. The base is equipped with a biconical connector providing 3 reading angles. Large and stable base. Polycarbonate.



163 321 Height 10 mm

Per 50

Medium and higher base holder for label First

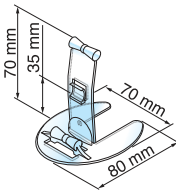

Designed to attach First labels. Equipped with a biconical connector providing 3 reading angles. Different heights available, 2 labels can be attached. Polycarbonate.



163 307 Height 70 mm

Per 50

163 305 Height 120 mm

Per 50

Ice pick for label First

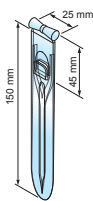

Ideal for seafood and fish products labels. Designed to attach First labels. Equipped with a biconical connector providing 3 reading angles. Different heights available. Polycarbonate.



163 603 Height 150 mm

Per 50

163 605 Height 300 mm

Per 50



... did you know?

R

For food-quality use

The base and pick connectors are made of clear polycarbonate. Discreet, they are suitable for contact with food.

A slot allows the presentation of a visual (0,4 to 1,5 mm thick). The biconical connectors allows to angle display in 3 positions (-25°, 0°, 25°).



Pick for FIRST label

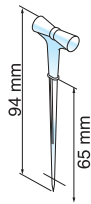

Designed to attach First labels. Equipped with a biconical connector providing 3 reading angles.



163 301 Simple pick height 94 mm

Per 50

163 303 Double pick height 94 mm

Per 50

FIRST label pinch

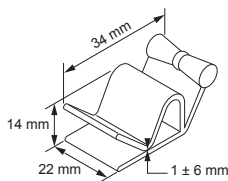

Positions the First label on the dish or shelf. Equipped with a biconical connector providing 3 reading angles. In PC.



163 617 Pinch for wide dishes 1 to 6 mm

Per 50

163 619 Pinch for wide shelves 6 to 12 mm

Per 50

Extension for FIRST labels, 50 mm

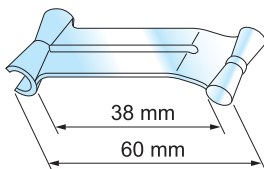

Goes onto base holders, plate clips and shelf clips. Improves visibility of the information and increases the possibilities for angling the label.



163 621 50 mm extension

Per 50

Adaptor for traditional labels

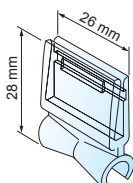

Design to attach traditional labels on First bases. Providing 3 reading angles thanks to the biconical connector.



163 601 Adaptor for traditional labels

Per 50

Double metal pinch clip for traditional label

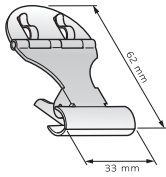

Designed to clip onto thin plates, suspends engraved labels.
Stainless steel.



163 615 Height 62mm - Width mm

Per 50

Socle métal à poser

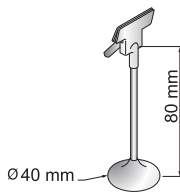

Designed for labelling in the front window, ideal for bakery and pastry sections.
Chrome clip suitable for food use.



163 607 Height 80 mm
163 609 Height 120 mm

Per 10
Per 10

Adhesive plastic pick

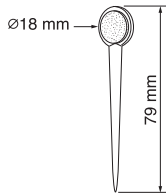

For presenting information and promotion visuals.



117 105 Adhesive white plastic pick 79 mm

Per 100

Insert plastic pick

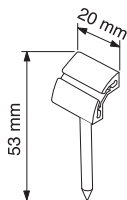

Plastic pin, white for dial price label.



117 102 Plastic pick for label 53 mm

Par 100

Adhesive product name font

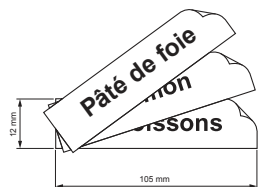

Easy to use. You just need to stick the name of the product on the label.
Clear background available in black or white lettering.



830 530	Delicatessen - Catering black lettering (860 product names)	Per unit
830 630	Delicatessen - Catering white lettering (860 product names)	Per unit
830 531	Butcher shop black lettering (395 product names)	Per unit
830 631	Butcher shop white lettering (395 product names)	Per unit
830 533	Dairy area black lettering (295 product names)	Per unit
830 633	Dairy area white lettering (295 product names)	Per unit
830 532	Fish section black lettering (372 product names)	Per unit
830 632	Fish section white lettering (372 product names)	Per unit





... did you know?

Regulations impose the following information: commercial name, the scientific name of the species and the zone where caught and the production method are indicated on the label or an appropriate mark for fish and aquaculture products offered for retail sale, including imported products. The fish pick brings your fish section into conformity.

Fish pick

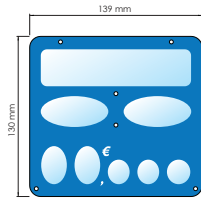

215 923 Fish pick + Price bundles

Compliant with the new legislation. The fish pick has different inserts providing complete information for your products. (inserts sold separately). In PC.



Per 10

Fishing area insert kit



215 927 Fishing location insert (252 names)

Allows to communicate on the zone where the fish were caught.



Kit

Fish name kit



215 929 Fishing name insert (450 names)

Allows to communicate on the name of the fish species.



Kit

Fishing method insert kit

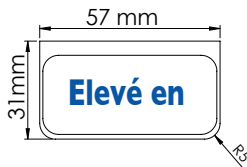

215 925 Fishing method insert (128 names)

Allows to communicate on the fishing method.



Kit

... did you know?

Use FIRST with the fish labelling board in your fish sections! Find all the elements on page 42.



... did you know?

R

Display your prices on Electronic labels in the Fruits & Vegetable section with the F&V electronic label slate!



F&V electronic label slate DM110 230 x 185 mm

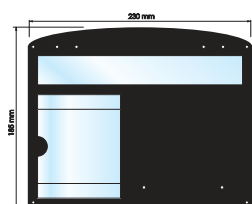

Designed to fix Pricer DM110 electronic label in the Fruits and Vegetables section. Comprised of a black slate with 2 alu fastening lugs + 2 sections for inserting communication supports. Associate a Pricer DM110 electronic label. In impact PS.



662 321 203x185mm - black

... did you know?

R

Have your Fruit & vegetable slates customised: on PVC, mini slates, with cut-outs and prints, your dimensions, according to your specifications; contact us!



Fruit and vegetable price board, small model

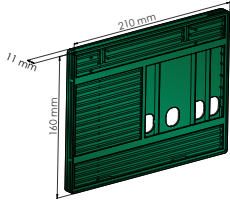

662 307 Green 3435C Fruit and vegetable price board

For the fruit and vegetable section. Comprised of 4 white digit bundles and 2 suspension hooks. Compliant with the new origin legislation. To be associated with the various inserts. In ...



Per 10

Statutory mentions, erasable



744 627 Statutory mentions, erasable

Allows to communicate on the statutory mentions on the Fruit and vegetable price board small holder.



Per 10

Fruit and vegetable product name kit



744 347 F&V product name kit (241 names)

Allows to communicate on fruits and vegetables names on the Fruit and vegetable price board small holder.



Kit

Origin kit

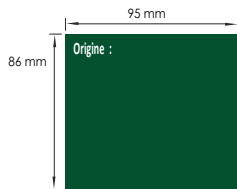

744 353 Origin kit : 310 names

Allows to communicate on the origin of the fruits and vegetables on the Fruit and vegetable price board small holder



Kit

Hooks

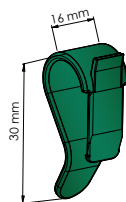

800 413 Hooks (only)

Allows to hook up the Fruit and vegetable price board small holder.



Per 50

... did you know?

Since 1 February 2010, regulations require the mentioning of the origin of the products in a character size the same as that for the price. Our kits bring into compliance those label-holders for which the character size is less than or equal to 45 mm.



Fruit and vegetable price board, large model

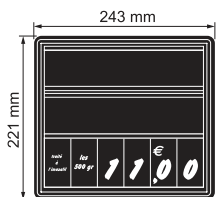

For the fruit and vegetable section. Comprised of 6 black digit bundles (4 digits + conditioning + treatment). Metal hooks. Compliant with the new origin legislation. To be associated with the various inserts.

In PE.



662 201	Black Fruit and vegetable price board	Per 10
662 305	Green Fruit and vegetable price board	Per 10
744 625	Statutory mentions, erasable	Per 10
744 345	Kit of 570 name fonts	Kit
183 005	Code labels for weighing machine, no. 1 to 100	The set

Label clip for Fruit and vegetable price board

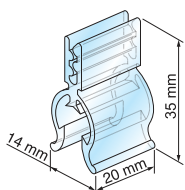

Designed to adapt to fruit and vegetable label-holders for communication supports.



800 411	Label clip for Fruit and Vegetable price board	Per 100
----------------	--	---------

PROMOTION Label

Fit into the label clip 800 411.



756 445	PROMOTION Labels	Per 50
----------------	------------------	--------



White chalk stick

Designed to erase your communication with water on slate supports.

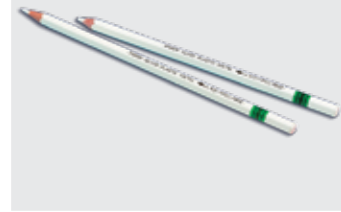

184 200

White chalk pencil

Per 12

White felt-tip pen

Designed to erase your communication with water on mini slate supports.



414 003

2.5 mm tip

Per 12

414 047

8.5 mm tip

Per 6

Ink and thinner

1 L container.
Use with felt-tip pens and marker tips. Available in several colours. Mix the thinner with inks to facilitate application or use it to clean your felt-tips.



411 001

Black Ink

Per 4

411 005

Red Ink

Per 4

411 007

Blue Ink

Per 4

411 009

Dark green Ink

Per 4

411 011

Thinner 1 L container

Per 4

Pens

Designed to create your promotional posters.



413 001

Canister with 4 felt-tip pens (4 sizes)

Per unit

413 017

Spare marker tip 51 x 25 mm

Per unit

413 015

Spare marker tip 37 x 16 mm

Per unit

413 013

Spare marker tip 20 x 13 mm

Per unit

413 011

Spare marker tip 10 x 7 mm

Per unit

413 021

Kit of 4 marker tips

Kit

R



NO
BISPHÉNOL
A

Hoppers



➤ **For all types of small products
(Except powders and liquids):**

- Hygienic system: pouring spout with handle, no contact with the food
- Capacity: 8 litres, 13 litres or 19 litres
- BPA-free copolyester: strong, easy to clean
- NSF-EC certified (conform with USA/EU food standards)

Discover our range on page 91.

Bins with scoops



➤ **For all types of larger products:**

- Customer self-service using a scoop or tongs
- Top-filling
- Capacity: 12 litres, 18 litres or 27 litres
- BPA-free copolyester: strong, easy to clean
- NSF-EC certified (conform with USA/EU food standards)

Discover our range on page 94.

Fixtures and accessories



- Traditional metal hoppers can be used on gondolas.
- Customised fixtures possible (metal, wood, etc.). Contact us.

- Bags, tongs, scoops, etc.(page 94)

Offer the best to your customers:

- **Make sure your range stands out thanks to innovation:** food (confectionery, etc., pet food, non-food (seeds, screws, etc.)
- A wide range: 33% more product references
- **Savings:** Reduced packaging cost (15 - 35% of prices)
- **Customised services:** quantity control



Aim for the best

- **Increased sales: additional sales**
- **Customer loyalty and acquisition:** an innovative, appealing and diversified range
- **Operational gains:** reduced management costs
- **Positive brand image:** :





...how does it work?



- 1 > **REVERSIBLE:** asymmetrical to adapt to traditional or gravity configurations.
- 2 > **VERSATILE:** a full range of individual stop rails to insert into the front edge of the dividers to maintain the products.
- 3 > **ROBUST:** A reinforced attachment ensures a perfect fixing on the divider in the fastening rail.
- 4 > **EASY & QUICK TO INSTALL:** a rear fastening system that facilitates installing and adjusting dividers at the back of the shelf.



CLARIFY YOUR OFFER

Shelf dividers

Shelf management

Automatic facing management

Product merchandising

054
V

Reverso Divider Small



new

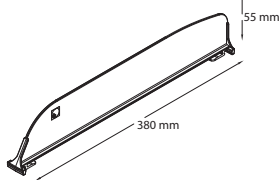

Designed to organise your shelves. Height 55mm: Ideal for small packagings. Reversible. To be used in the front with traditional rails and at the rear with your choice of traditional or REVERSO rails (fast rear attachment system integrated). Available in several lengths. In PET.



125 911	Clear - 55HtX 280Lmm	Per 50
125 913	Clear - 55HtX 330Lmm	Per 50
125 914	Clear - 55HtX 360Lmm	Per 50
125 915	Clear - 55HtX 380Lmm	Per 50
125 917	Clear - 55HtX 430Lmm	Per 50
125 918	Clear - 55HtX 460Lmm	Per 50
125 919	Clear - 55HtX 480Lmm	Per 50

...did you know?



Save time! The REVERSO rear attachment system allows for effortless fastening at the back of the shelf. It also allows the facings to be adjusted more easily. Find the Reverso rails on page 58.

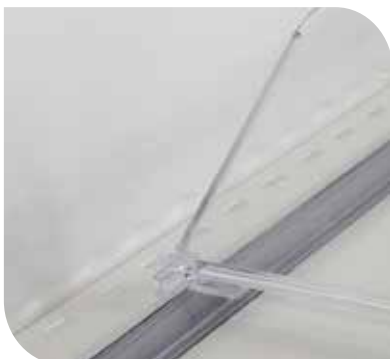
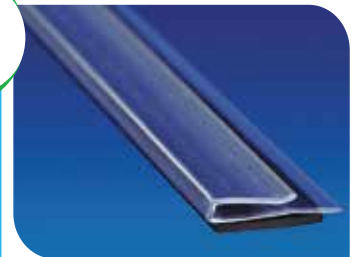

DARE THE COLOUR DIVIDERS!

CONSULT US

Segment and boost your offer by opting for colour dividers! Customisation possible from 5000 units (single or full colour). Contact us!



Reverso Divider Medium



new

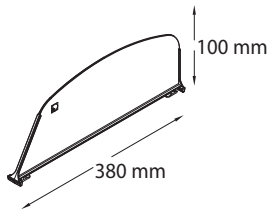

Designed to organise your shelves. Height 110m: Ideal for medium-size packagings. Reversible. To be used in the front with traditional rails and at the rear with your choice of traditional or REVERSO rails (fast rear attachment system integrated). Available in several lengths. In PET.



125 931	Clear - 100HTX 280Lmm	Per 25
125 933	Clear - 100HTX 330Lmm	Per 25
125 934	Clear - 100HTX 360Lmm	Per 25
125 935	Clear - 100HTX 380Lmm	Per 25
125 937	Clear - 100HTX 430Lmm	Per 25
125 938	Clear - 100HTX 460Lmm	Per 25
125 939	Clear - 100HTX 480Lmm	Per 25

...did you know?



REVERSO individual stop rails are compatible with the range of REVERSO dividers. They fit onto the front edge of each divider and are inserted into the front fastening rail. They maintain the products and as such guarantee clear and orderly shelves. Find the full range of REVERSO individual stop rails on page 59.



Reverso Divider XL



new

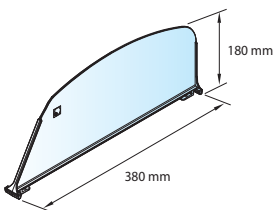

Designed to organise your shelves. Reversible. Height 180mm: Ideal for large packagings. To be used in the front with traditional rails and at the rear with your choice of traditional or REVERSO rails (fast rear attachment system integrated). Available in several lengths. In PET.



125944	Clear - 180HTX 380Lmm	Per 25
125946	Clear - 180HTX 480Lmm	Per 25
125948	Clear - 180HTX 580Lmm	Per 25

...did you know?



In the framework of our CSR commitment and our AIR programme, we are setting up actions aimed at limiting the use of polluting materials. As such, across the entire REVERSO line, Sitour has committed to using cardboard packaging without adhesive, which is easier to recycle.



...how does it work?

FLEXIBILITY & SIMPLICITY! With the range of breakable dividers, adjust the length of your dividers according to the depth of your shelves! Breakable every 25mm and provided with an attachment at every breakable point, the range of breakable dividers offers you a high degree of flexibility in your installations!

R



Breakable divider XS

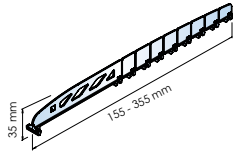

Designed to organise your shelves. Height 35 mm: Ideal for all small packagings. Breakable from 155 to 355 mm every 25 mm, they adapt rapidly to the different shelf depths. In PC.



125 971

Clear - 35Htmm X 155 to 355Lmm

Per 50

...did you know?

REVERSO individual stop rails are compatible with the range of BREAKABLE dividers. They fit onto the front edge of each divider and are inserted into the front fastening rail. Find the full range of REVERSO individual stop rails (page 71).

R



Breakable divider small

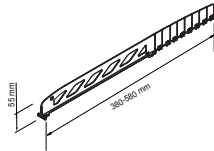

Designed to organise your shelves. Height 55 mm: Ideal for small packagings. Breakable every 25 mm, they adapt rapidly to the different shelf depths. In PC.



125 981

Clear - 55Htmm X 155 to 355Lmm

Per 50

125 985

Clear - 55Htmm X 280 to 480Lmm

Per 50

125 983

Clear - 55Htmm X 380 to 580Lmm

Per 50

...did you know?

In the framework of our AIR programme, we are working on reducing of the materials portion of our products. The objective is to limit the impact of our products on the environment while still retaining optimum functionality. BREAKABLE dividers are a perfect illustration of this!

R



Breakable divider Medium

new

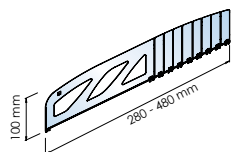

Designed to organise your shelves. Height 100 or 100mm. Ideal for medium-size packagings. Breakable every 25 mm, they adapt rapidly to the different shelf depths. In PC.



125 984

Clear - 100Htmm X 180 to 380Lmm

Per 50

125 989

Clear - 100Htmm X 380 to 580Lmm

Per 50

...how does it work?

R

CLASSIC FASTENING RAILS : The fastening system with traditional rails is an «entry» system (the divider attachment is inserted between the rails) which perfectly maintains the divider in the rail on the shelf. Traditional rails are available with a magnetic base (for metal shelves) and with an adhesive base (for other supports), in different widths according to the desired resistance.



Adhesive rail narrow base Clear

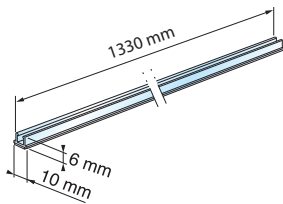

Maintains dividers on all types of smooth and clean supports. Adhesive narrow base with a 9 mm width. Accepts most dividers on the market. PVC adhesive base.

**123 109**

Clear - 9widthX1330Lmm

Per 10

Adhesive rail standard base Clear

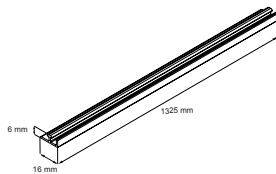

Maintains dividers on all types of smooth and clean supports. Accept the major dividers on the market. PVC adhesive base.

**123 112**

Clear - 16widthX1000Lmm

Per 10

123 113

Clear - 16widthX1245Lmm

Per 10

123 120

Clear - 16widthX1325Lmm

Per 10

Magnetic rail standard base White

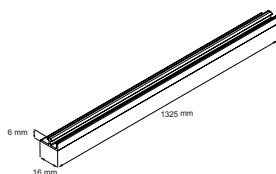

Maintains dividers on metal shelves. Magnetic base with a 16 mm width. Accepts most dividers on the market. PVC magnetic base.

**123 122**

White - 16widthX1000Lmm

Per 10

123 125

White - 16widthX1245Lmm

Per 10

123 130

White - 16widthX1325Lmm

Per 10

Magnetic rail standard base Black

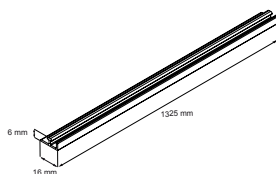

Maintains dividers on metal shelves. Magnetic base with a 16 mm width. Accepts most dividers on the market. PVC magnetic base.

**123 173**

Black - 16widthX1000Lmm

Per 10

123 174

Black - 16widthX1245Lmm

Per 10

123 134

Black - 16widthX1325Lmm

Per 10

reverso®

...how does it work?

SAVE TIME, SIMPLE TO HANDLE! The REVERSO rail attachment system allows for effortless rear fastening of REVERSO dividers at the back of the shelf. It also allows the facings to be adjusted more easily. They are compatible only with REVERSO dividers.



Reverso rear rail Clear

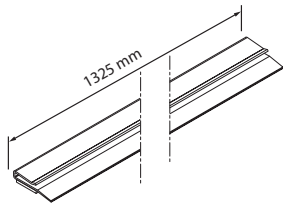

Maintains the REVERSO dividers at the rear of the shelf.
Available with an adhesive or magnetic base and in several lengths.
PVC.



125 951	Clear - 18mm widthX1000Lmm - Magnetic	Per 10
125 953	Clear - 18mm widthX1245Lmm - Magnetic	Per 10
125 954	Clear - 18mm widthX1285Lmm - Magnetic	Per 10
125 955	Clear - 18mm widthX1325Lmm - Magnetic	Per 10
125 959	Clear - 18mm widthX1325Lmm - Adhesive	Per 10

...did you know?

Organise your wire shelves! Simple to install, discrete, it accepts all dividers in the Sitour range!



Wire shelf rail

new

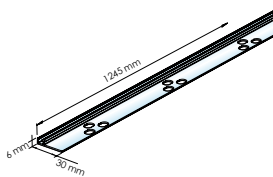

Integrates onto wire shelves and for the insertion of dividers.
Installs with adapters 123 142 (4 per rail). PVC.

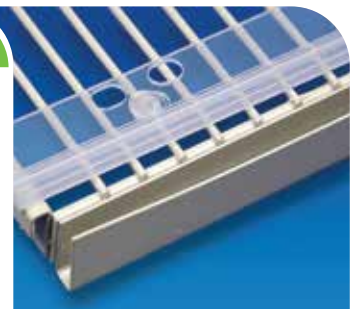

123 141	Clear - Width30X1245Lmm	Per 10
123 143	Clear - diameter 12mm	Per 50



...how does it work?

REVERSO INDIVIDUAL STOP RAILS :

FLEXIBLE, ASTHETIC & ROBUST! REVERSO individual stop rails are positioned on the edge at the front of REVERSO and BREAKABLE dividers and as such maintain the products at the front of the shelf. Made of PET, they are highly robust and transparent!



Reverso Stop Rail Small

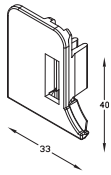

Designed to maintain small-size products at the front of the shelf, to the left or right of the divider. Fits onto the edge at the front of the divider and inserts into the rail for reinforced maintaining. Can be installed on horizontal or gravity feed shelves.



125 901	Clear - T - 40HtX40Lmm	Per 50
125 903	Clear - L (R+L) - 40HtX33Lmm	Per 10

Reverso Stop Rail Medium

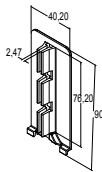

Designed to maintain medium-size products at the front of the shelf, to the left or right of the divider. Fits onto the edge at the front of the divider and inserts into the rail for reinforced maintaining. Can be installed on horizontal or gravity feed shelves. In PET.



125 905	Clear - T - 90HtX740Lmm	Per 50
125 907	Clear - L (R+L) - 90HtX33Lmm	Per 10

...did you know?



EASY FILLING!

The fins of the saloon stop fold back to facilitate filling the shelf and automatically return to their initial position to maintain the products.



Flexible Saloon Stop



Designed to maintain small-size products at the front of the shelf, to the left or right of the divider. Fits onto the edge at the front of the divider. Compatible with all SITOUR dividers. Flexible fins. PVC.



125 011	Clear - T 60HtX25Lmm	Per 50
125 013	Clear - T 120HtX25Lmm	Per 25

CLARIFY YOUR OFFER
Shelf dividers
Shelf management
Automatic facing management
Product merchandising

Front stop rail 90°, 30mm high

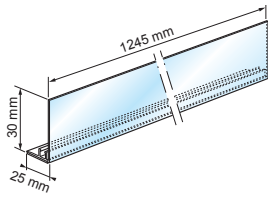

Designed to maintain small-size products at the front of the shelf and fasten the dividers. Front stop 30 mm high with integrated divider fastening rail. Adhesive or magnetic base. PVC.



123 203	30HtXwidth25XL1245mm - Adhesive	Per 10
123 205	30HtXwidth25XL1325mm - Adhesive	Per 10
123 251	30HtXwidth25XL1245mm - Magnetic	Per 10
123 253	30HtXwidth25XL1325mm - Magnetic	Per 10

Front stop rail 90°, 40mm high

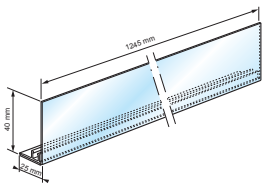

Designed to maintain small-size products at the front of the shelf and fasten the dividers. Front stop 40 mm high with integrated divider fastening rail. Adhesive or magnetic base. PVC.



123 413	40HtXwidth60XL1245mm - Adhesive	Per 10
123 419	40HtXwidth60XL1325mm - Adhesive	Per 10
123 421	40HtXwidth60XL1245mm - Magnetic	Per 10
123 423	40HtXwidth60XL1325mm - Magnetic	Per 10

Front stop rail 90°, 60mm high

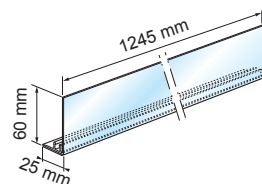

Designed to maintain medium-size products at the front of the shelf and fasten the dividers. Front stop 60 mm high with integrated divider fastening rail. Adhesive or magnetic base. PVC.



123 209	60HtXwidth25XL1245mm - Adhesive	Per 10
123 211	60HtXwidth25XL1325mm - Adhesive	Per 10
123 217	60HtXwidth25XL1245mm - Magnetic	Per 10
123 219	60HtXwidth25XL1325mm - Magnetic	Per 10

Front stop rail 90°, 80mm high

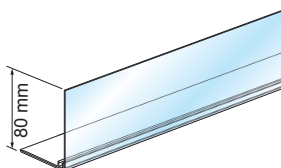

Designed to maintain large-size products at the front of the shelf and fasten the dividers. Front stop 80 mm high with integrated divider fastening rail. Adhesive or magnetic base. PVC.



123 429	80HtXwidth60XL1245mm - Adhesive	Per 10
123 435	80HtXwidth60XL1325mm - Adhesive	Per 10
123 437	80HtXwidth60XL1245mm - Magnetic	Per 10
123 439	80HtXwidth60XL1325mm - Magnetic	Per 10

Adhesive label-holder rail 20 mm

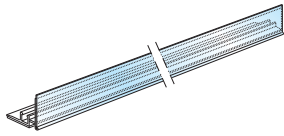

Allows to insert 20 mm high decostrrips or paper labels into it. Front stop fastening rail, suitable for divider installation. PVC.



123 223	Length 1325 mm - Adhesive	Per 25
123 225	Length 1245 mm - Adhesive	Per 25

Rounded segmenting rail

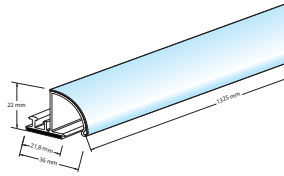

Curved shape favouring the readability of the information. Allows to insert 30mm high decostrrips or paper labels into it. Adhesive or magnetic base. Can receive dividers. PVC.



123 247	Length 1245 mm - Adhesive	Per 10
123 245	Length 1325 mm - Adhesive	Per 10
123 243	Length 1245 mm - Magnetic	Per 10
123 241	Length 1325 mm - Magnetic	Per 10

Adhesive stop rail profile

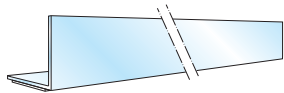

Height 30 mm, adhesive base. Without rail. PVC.



123 311	Length 1330 mm - Adhesive	Per 6
----------------	---------------------------	-------



...how does it work?



TRACK AND BACK SUPPORT KIT :

SIMPLE & HANDY! It allows flat packaging to be presented on the shelf as facing. It guarantees:

- Optimum visibility of the facings,
- quick identification of ruptures in stock,
- facilitated management of highlighted items.

It is used in traditional configuration (horizontal shelf)

Ideal for self-service delicatessen - catering.

The notch system of the track allows the back to be moved back easily by pressing on the base and provides a perfect lock of the back when it is loaded.



Magnetic back (without track)

new

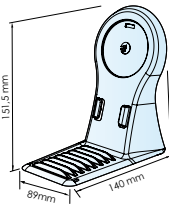

Designed to install flat packaging on the side for presentation as facing and better product visibility. Magnetic, installs on the metal shelf. PVC magnetic base.

124 211

Magnetic back



Per 10

Breakable back support and track kit

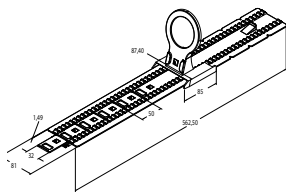

Designed to install flat packaging on the side for presentation as facing and better product visibility. Fits into the divider rail.

Comprised of a back support inserted into a track that can be broken every 50 mm between 330 and 580 mm. and an optional pull to facilitate the bringing forward of the back support. In PET.

124 205

Back support diammm - Breakable track from 330 to 580 mm

124 207

Breakable pull from 330 mm to 570 mm



Per 15

Per 15

Eco breakable back support and track kit

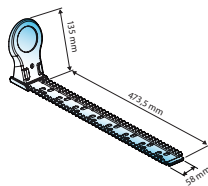

Designed to install flat packaging on the side for presentation as facing and better product visibility. Fits into the divider rail. Fit into wire shelves.

Comprised of a back support inserted into a track that can be broken every 50 mm between 330 and 480 mm. In SAN.

124 209

Eco breakable back support and track kit



Per 15

Bottom plate breakable back support and track kit

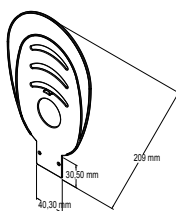

Designed to enlarge the size of the back support to maintain large-size products. Goes onto back supports 124 211 and 124 205. In PET.

124 108

Rounded format 209Htmm



Per 15

Eco back support and track kit

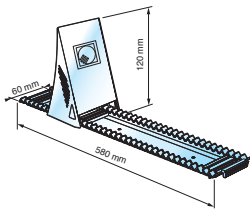

Designed to install flat packaging on the side for presentation as facing and better product visibility. Fits into the divider rail. Comprised of a back support inserted into a track with a depth of 380mm. In PET.



124 203 Back support 60widthX120Htmm - Track 380mm

Per 25

Bottom plate eco back support and track kit

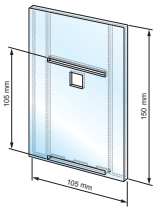

Designed to enlarge the size of the back support to maintain large-size products. Fits onto the eco back support 124 203. In PET.



124 105 Rectangle format 105widthx150Htmm

Per 25

124 107 Rectangle format 105widthx210Htmm

Per 25

...did you know?



Inform your customers about the exceptional absence of a product using the out-of-stock indicator back support. Customised to your sizes, colours and messages. Contact us!



Grooved anti-slide mat

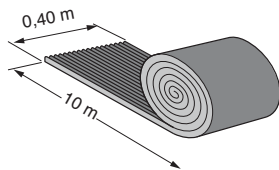

Prevents products from sliding on the shelf and guarantees a tidy shelf. Rubber made.



330 314 Black 0.4widthmx10Lm

Per unit

330 312 Black 1.2widthmx10Lm

Per unit

330 322 Grey 1.2widthmx10Lm

Per unit



Divider for round packaging

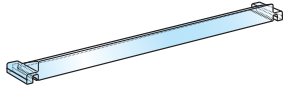

These dividers are designed for the presentation of round or oval packagings, all diameters. Ideal for cheese area. In PET.



111 103	Clear - Length 380mm	Per 20
111 105	Clear - Length 430 mm	Per 20
111 107	Clear - Length 480 mm	Per 20
111 111	Clear - Length 580 mm	Per 20

Display for round packaging, 4 facings

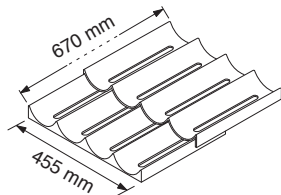

For presenting round packaging 115 mm in diameter. Ideal for cheese area. In PP.



796 001	White - 670DepthX455Width mm	Per unite
----------------	------------------------------	-----------

Telescopic shelf for round packaging

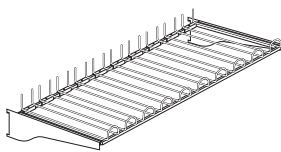

Presents round packaging as facing and facilitates maintenance. Set comprised of a telescopic frame and 10 modular arms. Fits with most cold fixtures. Metal.



115 110	White - 7 telescopic shelves (10 arms + 2 brackets per shelf)	Le kit de 7 tablettes
----------------	---	-----------------------



Gravity display

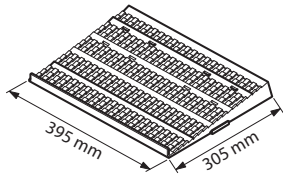

Presents products via gravity on shelves. Provided with notches to maintain the products. Available with or without a bottom. In ...



796 050	Base: White - 305DepthX395L mm	Per 10
112 007	Base + 1 bottom height 160mm + 1 bottom 110 mm	Per unite
112 011	Base + 2 bottoms height 160mm	Per unite

...did you know?



We produce customized dividers for cold and frozen tanks. Customised printing and cutting. Contact us!



Divider base profile

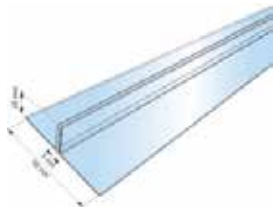

Receives customised dividers of a thickness of 3mm. Stable base. Available with magnetic strip on demand. PVC.



124 802	Length 680 mm	Per 50
124 807	Length 800 mm	Per 24
124 810	Length 1600 mm	Per 24



...how does it work?

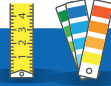

SHELF TRAYS :

SIMPLE, FLEXIBLE & EFFECTIVE! The breakable shelf tray system allows you to highlight a product family on the shelf as well as sustainable fix the facings on the shelf! Available in several widths, they can be broken and as such adapt to the length of the shelf.



Breakable shelf tray length 500mm

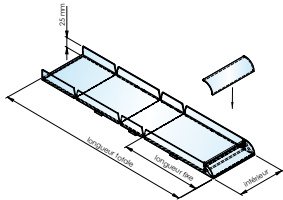

Organises products on the shelf. Available in several widths and can be broken to inside useful lengths of 172mm, 242mm and 372mm. They can be fastened together on the sides. Other widths available on demand. Crystal PS.



127 100	Outside 58.7 width X 500Lmm - inside 54 width X 470 Lmm - breakable	on offer
127 101	Outside 64.7 width X 500Lmm - inside 60 width X 470 Lmm - breakable	on offer
127 102	Outside 73.7 width X 500Lmm - inside 69 width X 470 Lmm - breakable	on offer
127 103	Outside 77.7 width X 500Lmm - inside 73 width X 470 Lmm - breakable	on offer
127 104	Outside 84.6 width X 500Lmm - inside 80 width X 470 Lmm - breakable	on offer
127 105	Outside 91.6 width X 500Lmm - inside 87 width X 470 Lmm - breakable	on offer
127 106	Outside 96.7 width X 500Lmm - inside 92 width X 470 Lmm - breakable	on offer
127 107	Outside 101.9 width X 500Lmm - inside 97 width X 470 Lmm - breakable	on offer
127 113	Outside 106.6 width X 500Lmm - inside 102 width X 470 Lmm - breakable	on offer
127 108	Outside 112.8 width X 500Lmm - inside 108 width X 470 Lmm - breakable	on offer
127 109	Outside 116.6 width X 500Lmm - inside 112 width X 470 Lmm - breakable	on offer
127 110	Outside 120.6 width X 500Lmm - inside 116 width X 470 Lmm - breakable	on offer
127 111	Outside 122.6 width X 500Lmm - inside 118 width X 470 Lmm - breakable	on offer





...how does it work?

CROSS MERCHANDISING :

Manage your facings! Breakable product presenters can be equipped with spring pushers to maintain perfect product facings.



Eco cross-merchandising strip

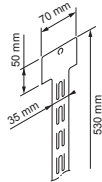

Presents blister-packed light packaging as cross-merchandising. Economical. Provided with a label-holder that can be customised. Total length 530 mm. PP.



145 001 Clear - Length 530mm - 12 Facings

per 50

Accordion cross-merchandising strip

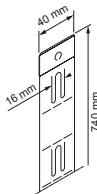

Presents blister-packed light packaging as cross-merchandising. Can be folded and is ready-to-use. Integrates directly into the conditioning thanks to its folding points at each point. Total length 740 mm.



145 003 Clear - Length 740mm - 12 Facings

per 50

Multipackaging cross-merchandising strip

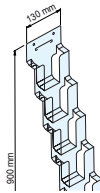

Presents 120mm-wide rectangular packaging as cross-merchandising (box or bag type) Depth can be adjusted to increase the capacity. Total length 970 mm.



145 007 Clear - Length 970mm - 6 Facings

per 100

Plastic pinch cross-merchandising strip

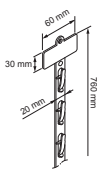

Presents blister-packed products as cross-merchandising thanks to pegs (max. load 400 g) or bagged products thanks to pinches (max. load 200 g). Rigid. Provided with a label-holder that can be customised 60x30 mm. Total length 780 mm. PP.



145101 White - Length 780mm - 12 facings

per 100

Metal pinch cross-merchandising strip

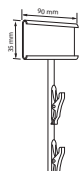

Presents blister-packed products as cross-merchandising thanks to pegs or bagged products thanks to pinches. For heavier packagings. Provided with a label-holder 90x30 mm. Total length 790 mm. Metal.



145 103 White - Length 790mm - 12 facings

Per 10

...did you know?

R

Fasten your cross-merchandising strips where you want thanks to the range of fastening accessories!



S hook

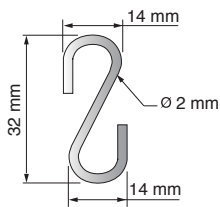

Ideal to hang cross-merchandising strips off shelves and gondola poles. Stable and easy hanging thanks to its specific shape and hook with double opening. Other formats on page 189. Metal.



792 428 Metal - Width 12X24Htmm - wire diameter 2mm

Oval metal split ring

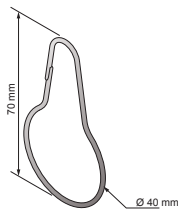

Ideal to hang cross-merchandising strips off shelves and gondola poles. Stable hanging thanks to its specific shape and easy opening system. Metal.



172 590 Metal - Height 70mm - Circle diameter 40mm-

Per 100

Metal hook

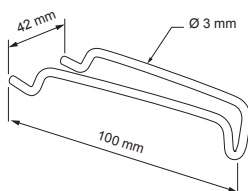

To hang cross-merchandising strips off perforated shelves. Inserts into the shelves. Presents cross-merchandising strips perpendicular to the shelf. Metal.



172 595 Metal - Length 100mm - wire diameter 3mm

Per 50

...did you know?



MULTI-POSITION CROSS-MERCHANDISING!

By easy manipulation of the angle, the magnetic block is rotated 90° and allows the fixation of your double peg-hook under metal shelves or against a metallic wall!



Multimag double peg-hook

new

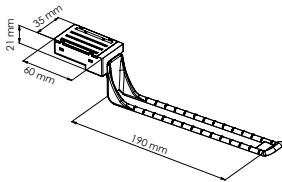

Presents blister-packed light packaging as cross-merchandising. For use under the shelf and against a metal wall or pole. Polyamide glass-fibre reinforced peg-hook (PA6.6) and base composed of a magnetic block and provided with the Multimag angle.



262 013

White - Length peg-hook 200mm

Per 10

...did you know?



Display your prices in cross-merchandising configuration thanks to double peg-hook label-holder! Fits to the front of the Multimag double peg-hook (30X25mm price label)!



CUSTOMIZED CROSS-MERCHANDISING SOLUTIONS

CONSULT US

We can provide fully customised cross-merchandising solutions.

We develop and manufacture cross-merchandising supports adapted to your packagings.

Consult us!



Shelf
dividers

Shelf
management

Automatic facing
management

Product
merchandising

Magnetic bag-holder L shape

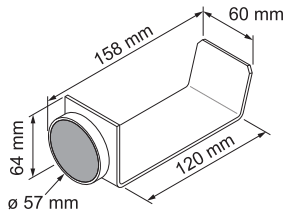

Designed to be fixed on any vertical surface. Magnetic strength 28 kg. PVC.

142 301 White - L - magnet 28kg



Per 25

Adhesive bag-holder L shape

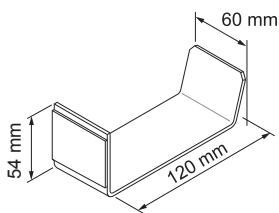

Designed to be fixed on any vertical surface. Ideal for your promotional operations. PVC.

142 317 White - L - adhesive



Per 25

Bag-holder straight

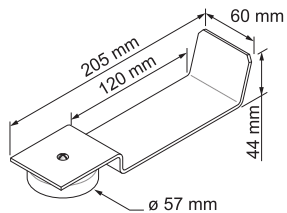

Designed to be fixed on any horizontal surface. Magnetic strength 28kg. PVC.

142 303 White - straight - magnet 28kg



Per 25

Metal bag-holder on stand

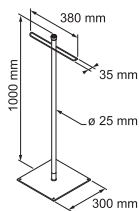

For displaying bags (BRI, frozen etc.) in the store. Comprised of a strip with a height of 1000mm with 2 perpendicular arms with a total width of 380mm. Very stable metal base.

142 305 White - 380width X 1000Ht mm



Per unite

...did you know?

R

Placed in the frozen section, aisle promos and at the registers, bag-holders provide additional sales space.



...may we help you?

AUTOMATIC FACING MANAGEMENT

Normal configuration:

Choose the force and size of the pusher according to the size, weight and shape of the product packaging!



Gravity configuration :

Gravity: There are different degrees of gravity:

- > Low (10°) for example for Easyroller
- > Highly pronounced (30°) for example for chocolate or bags of sweets.



Gravity can be expressed in two ways:

- > inverted gravity, i.e. the shelf is angled towards the rear; this gravity is often installed at the bottom of fixtures.
- > traditional gravity, i.e. the shelf is angled towards the front; this gravity is often installed at the top of fixtures.



Finally, traditional gravity can be installed in 2 different ways:

- > «Caught» gravity, i.e. when the accessories for organising the shelf are positioned in such a way as to catch a vertical line as facing despite the tilt on the shelves.
- > «Non-Caught» gravity, i.e. when the accessories for organising the shelf are positioned in such a way as to allow the products to exceed the vertical line with a tilt on the shelves.



...how does it work?

R

SPRING PUSHERS

For a tidy shelf and facings!

The pusher is the guarantee of an automatic adjustment in terms of facing each time a product is taken.

It ensures:

- Permanent facings
- Quick identification of ruptures in stock,
- Tidy shelf presentation.

The spring pusher is also:

- A secure spring in the back support
- A bottom plate that can be customised
- A guarantee to be fastened on any type of rail



Low-strength spring pusher

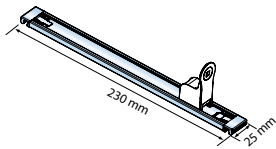

Automatically adjusts the facings for light packaging (< 100 g) towards the front of the shelf. To be fixed in divider rail at the front and the back of the shelf.

- Force 3 N. PVC rail - ABS endcap - POM back support



124 400	Width25X230Lmm	Per 20
124 401	Width25X280Lmm	Per 20
124 402	Width25X330Lmm	Per 20
124 403	Width25X380Lmm	Per 20
124 404	Width25X430Lmm	Per 20
124 405	Width25X480Lmm	Per 20

...did you know?

R

BE CAREFUL !

Pushers have to be supplemented with stop rails to maintain the products at the front of the shelf, dividers and therefore rails for guiding the products!



Medium-strength spring pusher

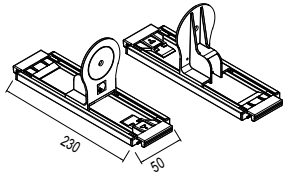

Automatically adjusts the facings for light packaging towards the front of the shelf. To be fixed in divider rail at the front and the back of the shelf. Force 5 N. PVC rail - ABS endcap - POM back support



124 410	Width50X230Lmm	Per 20
124 411	Width50X280Lmm	Per 20
124 412	Width50X330Lmm	Per 20
124 413	Width50X380Lmm	Per 20
124 414	Width50X430Lmm	Per 20
124 415	Width50X480Lmm	Per 20

...did you know?

Pushers can be integrated into breakable shelf trays by adding adhesive rails!

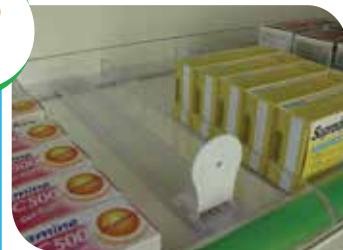

High-strength spring pusher

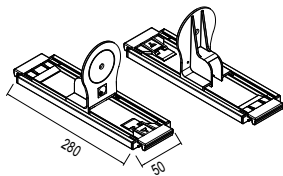

Automatically adjusts the facings for light packaging towards the front of the shelf. To be fixed in divider rail at the front and the back of the shelf. Force 8 N. PVC rail - ABS endcap - POM back support



124 421	Width50X230Lmm	Per 20
124 422	Width50X280Lmm	Per 20
124 423	Width50X330Lmm	Per 20
124 424	Width50X380Lmm	Per 20
124 425	Width50X430Lmm	Per 20
124 426	Width50X480Lmm	Per 20

Customisable extension for pusher

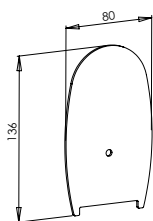

Enlarges the size of the pusher in order to push larger packagings. Fits onto the pusher with a snap fastener or fixing rivet (page XXX). Can be customised on demand. PVC.



124 431	Customizable extension for pusher	Per 20
----------------	-----------------------------------	--------

...how does it work?

To obtain a gravity shelf, use 10° or 30° gravity brackets (2 brackets per shelf). It is therefore possible on 1 element to place only one or a few gravity shelves and to leave the others in horizontal configuration. With shelves in gravity configuration, whether or not caught, all of the weight of the products is mechanically transferred to the front of the shelves and therefore is supported by the stop rail. It is therefore indispensable to provide gravity shelves with robust and well-fastened accessories. Discover our range below!



Gravity adhesive rail

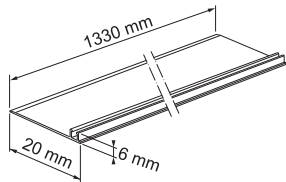

Maintains dividers on shelves in gravity configuration. Large base with double adhesive tape. Recommended use at the front and rear of the gravity shelf. Add REVERSO individual front stops. PVC.



123 305	Width20X1325Lmm
123 301	Width20X1000Lmm

Per 10
Per 10

REVERSO gravity stop rail

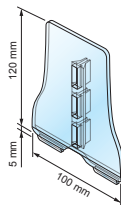

Maintains heavy products at the front of the shelf. Fits onto the edge at the front of the Reverso medium divider and inserts into the rail for reinforced maintaining. Ideal for confectionery. In PET.



125 001	Clear - T
125 003	Clear - L (R+L)

Per 50
By 10 lots

...did you know?

To maintain light products in gravity configuration, use the REVERSO traditional individual stop rails. Consult the range on page 59.



Front stop rail 60°, 40 mm high

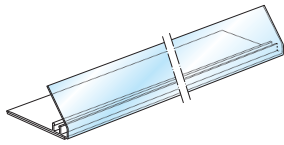

Designed to maintain small-size products at the front of the shelf and fasten the dividers. Stop rail with an angle at 60° in order to catch gravity. Adhesive wide base. PVC.



- | | | |
|----------------|---------------------------------|--------|
| 123 409 | 40HtXwidth60XL1245mm - Adhesive | Per 10 |
| 123 415 | 40HtXwidth60XL1325mm - Adhesive | Per 25 |

Front stop rail 60°, 80 mm high

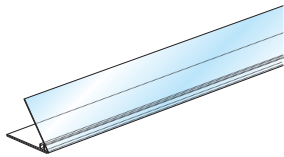

Designed to maintain medium-size products at the front of the shelf and fasten the dividers. Stop rail with an angle at 60° in order to catch gravity. Adhesive wide base. PVC.



- | | | |
|----------------|---------------------------------|--------|
| 123 431 | 80HtXwidth60XL1325mm - Adhesive | Per 25 |
|----------------|---------------------------------|--------|

Adjusted gravity pusher

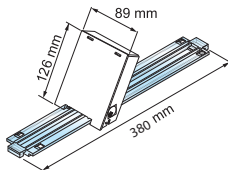

Ensures that products slide to the front of the shelf in gravity configuration. Fits onto the fastening rail of the divider. Weight can be adjusted. PC rail - PP back support



- | | | |
|----------------|---|--------|
| 126 007 | Back support Width89Xhigh126mm - rail 380L mm | Per 20 |
| 126 011 | Back support Width89Xhigh126mm - rail 480L mm | Per 20 |

White slide plate

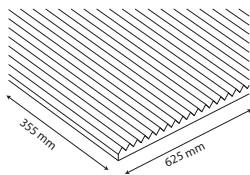

Encourages products to slide to the front of the shelf in gravity configuration. Lays on the shelf and under the divider. PVC.



- | | | |
|----------------|-----------------|--------|
| 123 701 | Width329X625Lmm | Per 10 |
|----------------|-----------------|--------|

Sliding profile for divider

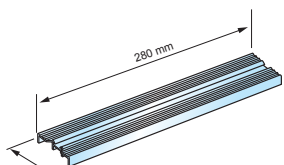

Encourages products to slide to the front of the shelf. Ideal to merchandise block chocolate in gravity feed configuration. Fits onto the base of Reverso dividers. Available in several lengths. POM.



- | | | |
|----------------|----------------|--------|
| 123 443 | Width40X280Lmm | Per 25 |
| 123 445 | Width40X330Lmm | Per 25 |
| 123 447 | Width40X380Lmm | Per 25 |
| 123 449 | Width40X430Lmm | Per 25 |
| 123 451 | Width40X480Lmm | Per 25 |

...how does it work?

R

AUTOMATIC FACING MANAGEMENT!

Positioned on a shelf with an angle of 10°, Easyroller is comprised of plates that can be assembled together and are fastened by a front rail in which a stop rail is inserted which maintains the products. At the rear another rail meets the plates and holds the device. Easyroller dividers allow the products to be separated from each other and to be guided towards the front of the shelf. Easyroller adapts to most shelf widths and depths. Available in kit (1 kit = 1 shelf) or per unit.

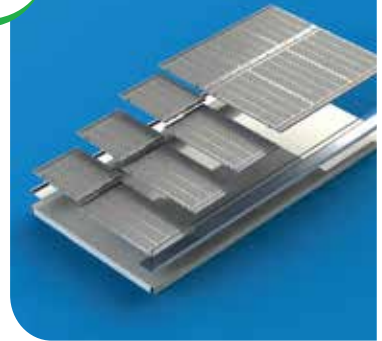

Easyroller kit 1330mm



Encourages products to slide to the front of the shelf in gravity configuration. Includes several modules to be assembled for a shelf 1330mm long, a front rail with a stop rail 80mm high and a rear rail. Available for different shelf depths. Available in grey or black (recycled materials).



Grey: 124621 - Black 124622	Easyroller kit for shelf 1330 x 300 mm	Kit
Grey: 124623 - Black: 124624	Easyroller kit for shelf 1330 x 400 mm	Kit
Grey: 124625- Black 124626	Easyroller kit for shelf 1330 x 500 mm	Kit
Grey: 124627 - Black: 124628	Easyroller kit for shelf 1330 x 600 mm	Kit

Easyroller kit 1250mm

Grey: 124611 - Black: 124612	Easyroller kit for shelf 1250 x 300 mm	Kit
Grey: 124613 - Black: 124614	Easyroller kit for shelf 1250 x 400 mm	Kit
Grey: 124615 - Black: 124616	Easyroller kit for shelf 1250 x 500 mm	Kit
Grey: 124617- Black: 124618	Easyroller kit for shelf 1250 x 600 mm	Kit

Easyroller kit 1000mm

Grey: 124601 - Black: 124602	Easyroller kit for shelf 1000 x 300 mm	Kit
Grey: 124603 - Black: 124604	Easyroller kit for shelf 1000 x 400 mm	Kit
Grey: 124605 - Black: 124606	Easyroller kit for shelf 1000 x 500 mm	Kit
Grey: 124607 - Black: 124608	Easyroller kit for shelf 1000 x 600 mm	Kit





...did you know?

Compose your Easyroller shelves yourself by assembling the modules, rear rails, front rails and stop rails to the sizes (length and depth) of your shelves!!!

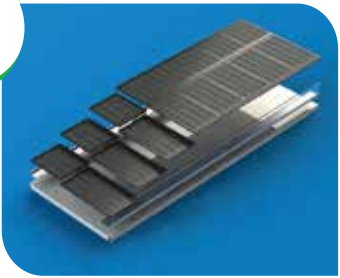

Easyroller slide module width 166mm



Encourages products to slide to the front of the shelf in gravity configuration. Fit together and as such allow the shelf to be covered. Add front and rear alu rails as well as a stop rail. Available in grey or black (recycled materials).



Grey: 124651 - Black: 124652	Slide module Width166X200L mm	Per unit
Grey: 124653 - Black: 124654	Slide module Width166X300L mm	Per unit

Easyroller slide module width 85mm



Encourages products to slide to the front of the shelf in gravity configuration. Fit together and as such allow the shelf to be covered. Add front and rear alu rails as well as a stop rail. Available in grey or black (recycled materials).



Grey: 124655 - Black: 124656	Slide module Width85X200L mm	
Grey: 124657 - Black: 124658	Slide module Width85X300L mm	

Easyroller divider



Separates the products from each other and guides them to the front on the Easyroller slide modules. Inserts into the slots at the ends of the slide modules. In PET.



124 691	Easyroller divider 300mm	Per unit
124 693	Easyroller divider 400mm	Per unit
124 695	Easyroller divider 500mm	Per unit
124 697	Easyroller divider 600mm	Per unit

...did you know?

Easyroller can also be used on a half-shelf or a quarter-shelf! We can provide ready-to-use gravity supports to your size, equipped with the Easyroller solution, to be installed directly on the shelf! Contact us!

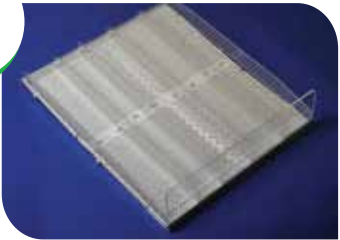

Easyroller front rail

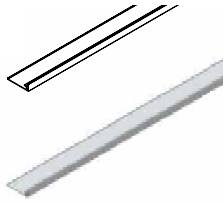

Retains and brings together the Easyroller slide modules. Is positioned to the front of the shelf under the slide modules. Receives the Easyroller front stop rail and as such blocks the products at the front of the shelf.
Aluminium.



124 679	Alu - Easyroller front rail 1000mm	Per unit
124 681	Alu - Easyroller front rail 1250mm	Per unit
124 683	Alu - Easyroller front rail 1330mm	Per unit

Easyroller front stop rail



Maintains the products in gravity with the Easyroller solution. Inserts into the Easyroller front rail to maintain the products.
In PET.



124 667	Clear - 40HtX1000Lmm	Per unit
124 669	Clear - 40HtX1250Lmm	Per unit
124 671	Clear - 40HtX1330Lmm	Per unit
124 673	Clear - 80HtX1000Lmm	Per unit
124 675	Clear - 80HtX1250Lmm	Per unit
124 677	Clear - 80HtX1330Lmm	Per unit

Easyroller rear rail

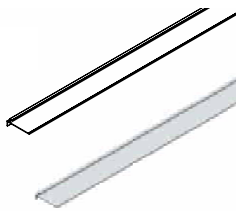

Retains and brings together the Easyroller slide modules. Is positioned to the rear of the shelf under the slide modules.
Aluminium.

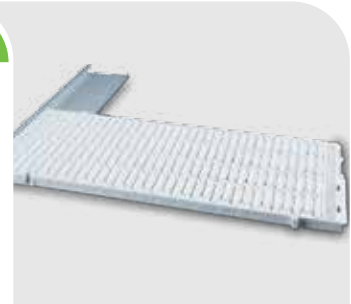

124 685	Alu - Easyroller rear rail 1000mm	Per unit
124 687	Alu - Easyroller rear rail 1250mm	Per unit
124 689	Alu - Easyroller rear rail 1330mm	Per unit

10° orientation bracket- steps of 25mm

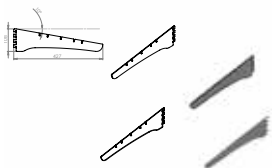

Give the shelf the angle - 10° - required for the proper operation of the Easyroller solution. Inserts into the racks in steps of 25mm. Use 2 brackets per shelf.
Metal.



124 701	White - Depth 300mm	Per unit
124 703	White - Depth 400mm	Per unit
124 705	White - Depth 500mm	Per unit

...how does it work?



Bulk also dry products (more or less small) to be sold as self-service, thus letting the customer choose the quantity and assortment. Bulk is expressed as sales surface by the equipment of a fixture (standard or customised) with hoppers and/or bins with scoops (or tongs) fastened to the fastening accessories (shoes, bases, shelves, loading tube). In order for this area to stay clean, a recovery bin has to be added under each row (in order to prevent products from falling on the floor) and to correctly delimit the area with effective signage (front signs, dome, stickers on the ground, etc.) and instructive communication (...how does it work?).



8-litres hopper



Offers self-service for products. Pouring spout with handle for bulk products. Holds 8 litres. FIFO system. Copolyester without Bisphenol A.



127 739

Width 10cm, height 53cm, depth 28cm (without base)

Per unit

13-litres hopper



Offers self-service for products. Pouring spout with handle for bulk products. Holds 13 litres. Available in 2 widths. System Copolyester without Bisphenol A.



127 755

Width 15cm, height 53cm, depth 38cm (without base)

Per unit

127 753

Width 15cm, height 53cm, depth 38cm with stirrer

Per unit

127 731

Width 10cm, height 68cm, depth 34cm (without base)

Per unit

19-litres hopper



Offers self-service for products. Pouring spout with handle for bulk products. Holds 19 litres. FIFO system. Copolyester without Bisphenol A.



127 751

Width 15cm, height 61cm, depth 28cm (without base)

Per unit

...did you know?



Bin range with a pouring spout and handle to serve the products simply and hygienically. The entire range of bins is 100% compatible for food use, made of copolyester - a highly resistant and transparent material - no Bisphenol A guaranteed!



Shelf
dividers

Shelf
management

Automatic facing
management

Product
merchandising

079
V

...did you know?

R

Hopper fastening accessories allow the hoppers to be fixed onto the shelves provided for this purpose. Available in 2 widths in order to adapt to the width of the hoppers. Compatible with the 8-litre, 13-litre and 19-litre hoppers.



Black base for hopper



Designed to fix the hopper on the shelf. Has a screw in the rear that maintains the base on the shelf. The hopper then fits into the base. For maintenance, just take the hoppers off its base. ABS.



- | | |
|----------------|---------------------------------|
| 127 761 | Black - for Hoppers width 10 cm |
| 127 763 | Black - for Hoppers width 15 cm |

Per unit
Per unit

Black shoe for hopper

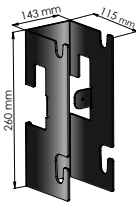

Designed to fix the hoppers on the loading tubes provided for this purpose. Available in 2 widths in order to adapt to the width of the hoppers. Compatible with the 8-litre, 13-litre and 19-litre hoppers. Metal, black.



- | | |
|----------------|------------------------------------|
| 127 901 | Black - for hoppers 13 litres 15cm |
| 127 903 | Black - for hoppers 13 litres 15cm |

Per unit
Per unit

Hydraulic arm for 19l hopper

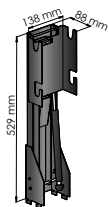

Designed to fix the 19-litre hoppers on the shelves provided for this purpose. System making it possible to access, via simple traction, the cover of the hopper for easy filling. Compatible with the 19-litre hoppers only.



- | | |
|----------------|------------------------------|
| 127 905 | Black - for 19-litre Hoppers |
|----------------|------------------------------|

Per unit

Shelf for hopper fastening



Designed to fix the black bases to the hydraulic arms whereon the hoppers are installed.
Perforated shelf. Available in several lengths and depths.
Metal, black.



127 933	Black - 400WidthX1330Lmm
127 931	Black - 300WidthX1330Lmm

Per unit
Per unit

Loading tube for shoes



Designed to receive the shoes whereon the hoppers are installed. Installs in the racks.
Available for Hermès 25 and Tégometal fixtures.
Metal, black.



127 911	Black - Hermès 25 - 1330Lmm
127 913	Black - Hermès 25 1000Lmm
127 915	Black - Tégometal 1330Lmm
127 917	Black - Tégometal 1000Lmm

Per unit
Per unit
Per unit
Per unit

Black crumb collector

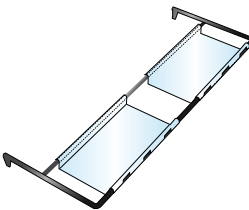

Designed to recover the products that fall. Installs on the racks of fixtures in steps of 25mm under each hopper row. Compatibility possible with other fixtures on demand. Comprised of a black metal wire holding 2 transparent plexi bins.



127941	Black - Hermès 25 1330Lmm with 2 bins
127943	Black - Hermès 25 1000Lmm with 2 bins

Per unit
Per unit

THE READY-TO-USE BIN SOLUTIONS

CONSULT US

If you would like a ready-to-use solution (fixture + hoppers + hopper accessories + dressing) contact us!!! We will be able to advise you as best as possible in your choice and will provide you with support until the bulk fixture is installed in your store!!



...did you know?

R

Range of bins with scoops (or with tongs) for rapid and handy service for more voluminous self-service products. The entire range of bins is 100% compatible for food use, made of copolyester - a highly resistant and transparent material - no Bisphenol A guaranteed!



Bin with scoop



Offers self-service for products. Bin for bulk products. Delivered with a scoop (tongs are possible). FIFO system. Copolyester without Bisphenol A.



127 775	Bin 17 litres, width 20 cm, height 33cm, depth 43 cm, delivered with scoop and cord	Per unit
127 779	Bin 27 litres, width 30 cm, height 33cm, depth 43 cm, delivered with scoop and cord	Per unit
127 789	Tongs for bin	Per unit

Slider for bins with scoop

Simplifies access to the cover of the bins to fill them by allowing them to slide to the front. Fits onto the scoop bin loading tube. Provided with a locking system. 2 sliders per bin. In PE.



127 781	Black - Right slider for bin with scoop	Per unit
127 783	Black - Left slider for bin with scoop	Per unit
127 785	Black - Central slider for bin with scoop	Per unit

Loading tube for bin with scoop



Receives sliders whereon the Bins with scoops are installed. Available in several lengths. Installs in the racks of Hermès 25 fixtures. Also available for Tégometal fixtures on demand. Metal, black.



127 923	Black - Hermès 25 for bins with scoop 1330mm	Per unit
127 921	Black - Hermès 25 for bins with scoop 1000mm	Per unit

CUSTOMISE YOUR BIN FIXTURE

Entrust us with your dressing for hopper fixtures. Front signage, segmentation, banners, etc. We will help you create a genuine Bulk shop that will grab the attention of your customers! !

CONSULT US



...how does it work?

THE EASYFACING

AUTOMATE FACING MANAGEMENT!

Easyfacing is a merchandising device for chilled, cold and dry fixtures that makes it possible to optimise the number of product facings, manage the section and commercial performance. - It is installed in almost all vertical chilled and cold fixtures. - The system can equip the fixture entirely or partially. - It is comprised of plates installed on loading tubes. - The plates are equipped with a pusher that ensures the product moves forward to the stop rail and as such guarantees automatic facing management, and therefore shelves that are always clean. The plates are available in different formats with varying pusher strengths in order to better adapt to the shape and the size of your packagings.

PRODUCT BENEFITS OF EASYFACING

- 1 > **ERGONOMIC:** Easy facing is both easy to install (on loading tubes) and easy to use (products are loaded from the front, automatic management)
- 2 > **FLEXIBLE:** Easyfacing adapts to most fixtures in the market and to most of the product packagings (choice of length and width, stop rail, pusher strength)
- 3 > **ESTHETIC:** It enhances the products (display on the side for product presentation as facing) and guarantees a tidy shelf at all times of the day (automatic facing management)
- 3 > **COMPLIES WITH HYGIENE & SAFETY RULES:** Easyfacing allows for good circulation of the cold air curtain as well as simplification in managing product rotation (Use-by date).

ADVANTAGES FOR YOU AND YOUR CUSTOMERS

Easyfacing is therefore:

- 1 > Simplification of the work of the section managers and optimisation of management costs
- 2 > Guarantee of a constantly tidy shelf and therefore increased product visibility
- 3 Customer satisfaction and growth in the sales of the segment!



Shelf
dividers

Shelf
management

Automatic facing
management

Product
merchandising

083
V

CLARIFY
YOUR OFFER

...how does it work?

R

THE FROZEN FIXTURE CONCEPT WORK, PRODUCT VISIBILITY GUARANTEED!

The Sitour Concept for Frozen fixtures offers:

- > **Product visibility:** ice cream is presented as facing, the offer is clarified and comprehensive.
- > **Automatic facing management:** the slight gravity of the peg-hooks allows the ice cream to automatically move down towards the front to the stop rail which gives the impression of a full shelf all day long.
- > **Flexibility:** compatible with shark type fixtures as well as chest type fixtures
- > **Hygiene & safety:** Free circulation of air and reduction in the formation of frost.
- > **Simplicity:** quick assembly and accessible to all (peg-hooks with slight gravity on loading tube)!



Shark ice cream fixture kit

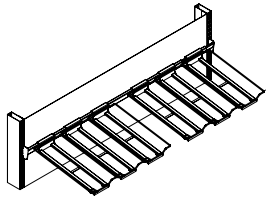

Designed to present ice cream as facing in a shark fixture and to guarantee constant product visibility. Kit comprised of 30 peg-hooks (6 bins deep) + 5 loading tubes.
Metal

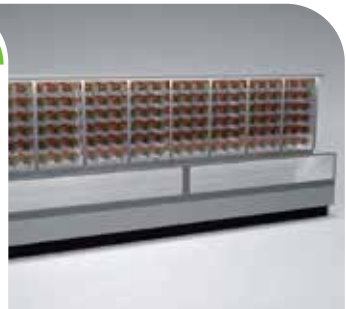

D 15 243 White - 30 peg-hooks + 5 loading tubes

Kit

Chest ice cream fixture kit

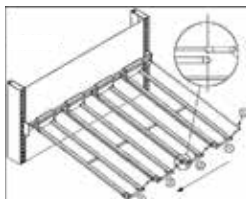

Designed to present ice cream as facing in a chest fixture and to guarantee constant product visibility. Kit comprised of 30 peg-hooks (9 bins deep) + 8 loading tubes.
Metal.



D 15 245 White - 30 peg-hooks + 8 loading tubes

Kit

...did you know?

R

Think about it! To display your prices clearly on the Ice cream fixture, you can use the peg-hook label-holders (electronic or paper) in the Sitour range! Find the peg-hook label-holder ranges on page 37 !



...how does it work?

R

THE ROUND PACKAGING CONCEPT WORK, PRODUCT VISIBILITY GUARANTEED!

The round packaging concept is an innovative concept comprised of arms positioned on a sliding structure. It offers:

> **Product visibility:** the products are positioned on the side, as such offer perfect visibility of the product facing for the customer. The offer is clear and comprehensive (+40% of facings), the shelf is more attractive (+20% in sales) and there are less management costs.

> **Flexibility:** This concept adapts to most cold fixtures (equipped with racks with 25mm spacing).

> **Hygiene and safety:** This concept guarantees free circulation of the air curtain and simplified maintenance, and better-managed rotations (telescopic drawer).



Telescopic shelf for round packaging

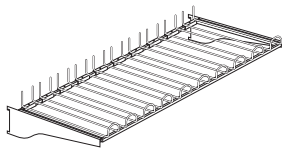

Presents round packaging as facing and facilitates maintenance. Set comprised of a telescopic frame and 10 modular arms. Fits with most cold fixtures. Metal.



115 110

White - 7 telescopic shelves (10 arms + 2 brackets per shelf)

Kit

...did you know?

R

THINK ABOUT IT !

To display your prices on the round packaging Concept, use the Freeline Clipavis profile with its individual label-holders (paper or electronic); find the range on page 16. You can also attach an individual paper or electronic label-holder to each arm; find the range on page 38-39.



Telescopic shelf for round packaging



Shark ice cream fixture kit

Shelf
dividers

Shelf
management

Automatic facing
management

Product
merchandising

085
V

CLARIFY
YOUR OFFER

...did you know?

R

Sitour has developed genuine know-how in designing standard or customised fixtures, in various materials (metal, wood, plexi, etc.), for various sections (sweets, salty, bulk, non-food, etc.) and various markets (specialty hypermarkets, supermarkets, Brands, etc.). Sitour provides support to its customers all throughout the project from defining the need, 3D design, prototypes, tests, deployment, delivery, assembly and follow-up at the point of sale. Entrust us with your fixture projects, we know how to surprise you!



...how does it work?

R

The premium solution for displaying small products!

Made of acrylic, polished edges, these small product displays will deliver their effect! Place them directly on the counter or in a front window, they will allow you to highlight new items and promotions! Available in clear, black or a colour on demand. Contact us!

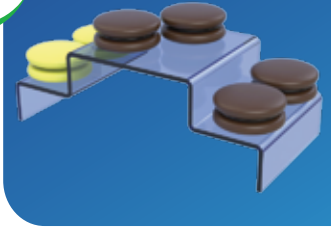

Product presentation staircase



new

For displaying small products. Has the shape of a 2 or 3 level staircase. To be installed. Clear or black. Other sizes available on request. Acrylic.



798 101

Clear - 2 steps 100 x 210 x 100 mm - 3 mm thick

Per 10

...did you know?

R

Display your products in a shop or front window thanks to our solutions with shelves, cubes, wardrobes on tight cables. Discover the entire range on chapter 6.



Product presentation bridge

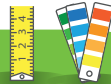

new

For displaying small products. Has the shape of a bridge. To be installed. Clear Acrylic.



798 111

Clear - 3 levels 100 x 310 x 150 mm

Per 15

Dual display



new

For displaying small- and medium-sized products. To be installed. Can be nested. Square or rectangular. Other sizes available on request. Acrylic.

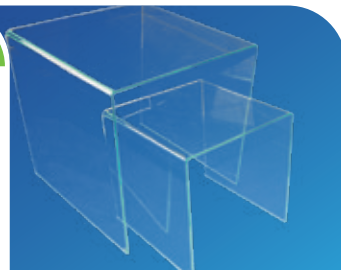

798 121

Clear - Square 2 levels 350 x 250 mm

Per 2

...did you know?

R

Display your products in a shop or front window thanks to our solutions with shelves, cubes, wardrobes on tight cables. Discover the entire range on chapter 6.



Shelf
dividers

Shelf
management

Automatic facing
management

Product
merchandising

087
V

CLARIFY
YOUR OFFER



FOCUS range = long-term decorations to ensure the products stand out on the shelf

A modular range

> The width and height of this solution can be adjusted to meet your requirements



• Highlight a product

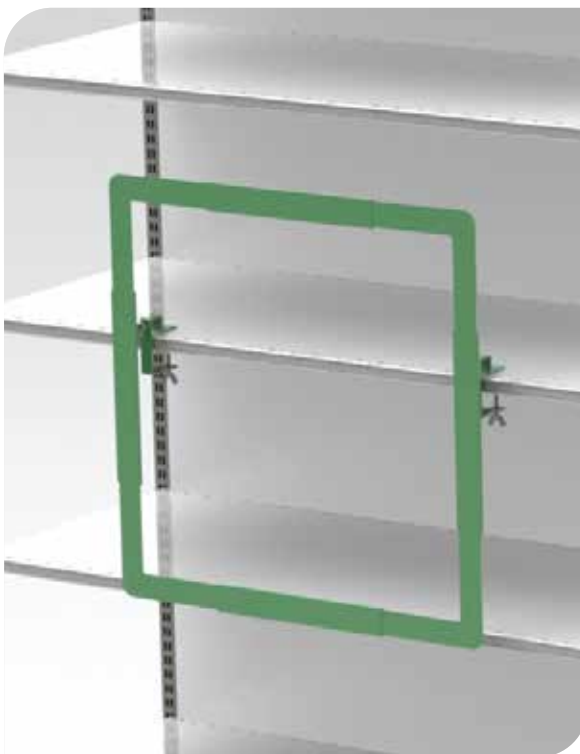

• Highlight a product range



• Highlight a gondola

A customisable range



• Sticker or micro suction cup



• Leds fonctionnant avec des piles boutons



• Front sign + curved POS

This range is easy to install



• Metal clamp pinches under the shelf rail



• 2 magnets under the shelf



... may we help you?

SELECTING A SUPPORT BASE AND WHERE TO USE IT?

Display on the floor		<ul style="list-style-type: none"> • L-shaped pallet banner hanger: 774 009 • L-shaped pallet banner hanger: 774 007 • Straight Magnum promokit, metal base: 774 001
Display on metal fixture	On or under metal shelf	<ul style="list-style-type: none"> • The range of Multimag + banner hangers: 841 209 - 841 211 - 841 219 - 841 213 - 841 215 • The range of Multimag banner hangers: 841 201 - 841 203 • Multimag accessories: 262 085 - 262 841 • The range of straight banner hangers: 841 613 - 841 610 - 841 609 • Maxi shark banner hangers: 841 707 - 841 709 • Magnetic clips for frames: 841 207
	On or against metal poles	<ul style="list-style-type: none"> • The range of Multimag + banner hangers: 841 209 - 841 211 - 841 219 - 841 213 - 841 215 • The range of Multimag banner hangers: 841 201 - 841 203 • Multimag accessories: 262 085 - 262 841 - 715 045 - 715 043 • Magnetic clips for frames: 841 207
	Metal gondola base	<ul style="list-style-type: none"> • The range of Multibase banner hangers: 841 521 - 841 517 - 841 511 - 841 515 - 841 513
Gondola roof display	Gondola	<ul style="list-style-type: none"> • Z-shaped magnetic poster hanger with poster clip: 841 621 • Z-shaped magnetic banner hanger with hooks: 841 623 • Multimag banner hanger + front sign holder: 841 215
	For gondola head	<ul style="list-style-type: none"> • L-shaped gondola head banner hanger: 841 901 • T-shaped gondola head banner hanger: 841 903 • Multimag banner hanger + front sign holder: 841 215
Island or tray display	Rummage bin (wire)	<ul style="list-style-type: none"> • Rummage bin banner hanger: 821 117 • Clear hooks for frame: 610 308 • Double clip pinch: 163 615 • Double pince with hinge: 163 403 • Label holder with hinge: 163 401 • Single wire basket facing gripper: 797 180 • The range of split rings: 792 311 - 172 580 - 172 582 - 172 583 - 172 584 • The Promokit range: 821 010 - 821 008 - 821 004 - 822 006
	Island	<ul style="list-style-type: none"> • The Promokit range: 821 010 - 821 008 - 821 004 - 822 006



Les potences

Shelf clips

Segmentation

IN-STORE
THEATRE

... how does it work?



MULTIMAG PLUS: MULTI-ORIENTATION & MULTI-FASTENING:

Multimag Plus is a banner hanger developed by Sitour Merchandising to dress up your shelves and animate your sales.

- With Multimag + angle the signage as you like!

The magnetic block's notched cap allows for angles from 0 to 180°.

- Multimag + is more choice in fastenings in order to adapt to your POS: open hooks, closed hooks, grippers, straight tube for front signs, telescopic tube for deep shelves or wide POS.



Multimag Plus banner hanger hooks

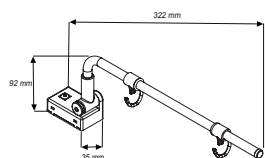

Fits onto and under the shelves or against metal poles and walls. The angle of the tube can be adjusted from 0 to 180°.

Reinforced magnet and elbow tube with diameter of 10 mm. Maximum poster weight is 1000 g. Aluminium Tube.

841 209 White base - Alu Tube - 2 ring hooks

841 211 White base - Alu Tube - 2 open hooks

Per 10

Per 10



Multimag Plus banner hooks BLACK

new

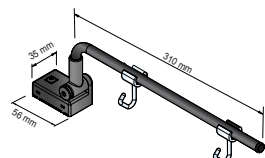

Fits onto and under the shelves or against metal poles and walls. The angle of the tube can be adjusted from 0 to 180°.

Reinforced magnet and elbow tube with diameter of 10 mm. Maximum poster weight is 1000 g. 100% black, ideal for black (or dark) surfaces. Black Aluminium Tube dyed in the mass.

841 212 Black base & tube - 2 open hooks

Per 10



Multimag Plus banner hanger gripper

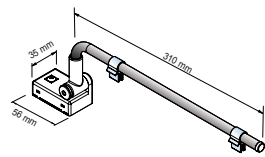

Fits onto and under the shelves or against metal poles and walls. The angle of the tube can be adjusted from 0 to 180°.

Reinforced magnet and elbow tube with diameter of 10 mm. Comprised of 2 grippers that can hang non-perforated banners. Aluminium Tube.

841 219 White base - Alu Tube - 2 grippers

797 180 Grippers 13mm in diameter

Per 10

Per 100



Multimag Plus banner gripper BLACK

new

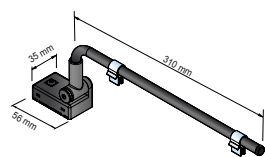

Fits onto and under the shelves or against metal poles and walls. The angle of the tube can be adjusted from 0 to 180°. Reinforced magnet and elbow tube with diameter of 10 mm. Comprised of 2 grippers that can hang non-perforated banners. 100% black, ideal for black (or dark) surfaces. Black Aluminium Tube dyed in the mass.

841 220 Black base and tube - 2 grippers

Per 10



ENTRUST YOUR POS TO US!

CONSULT US

Our graphics studio will support you in the design and production of your promotions and communication supports. Banners, front signs, shelf talkers, shelf boosters, segmentation... we are at your service.
Contact us!



Multimag Plus banner 42 cm

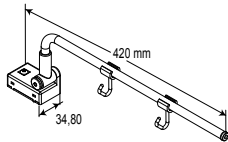

Fits under the shelves or against metal poles and walls. The angle of the tube can be adjusted from 0 to 180°.

Reinforced magnet and elbow tube 42 cm long and 10cm in diameter allow you to hand your banners.

Aluminium tube.

841 221

White base and alu tube - 42Lcm tube - 2 ring hooks



Per 10

... did you know?

To display your promotional offers in the frozen section, use the hanger for freezer pyramids (ref. 841121)!

R



Multimag Plus telescopic banner hanger

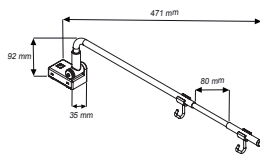

Fits onto and under the shelves or against metal poles and walls. The angle of the tube can be adjusted from 0 to 180°.

Reinforced magnet and telescopic elbow tube with diameter of 10 mm from 34 cm to 44 cm allowing you to hang your banners up to 400g .

Aluminium tube.

841 213

White base and Alu tube - Telescopic 34 to 43cm - 2 open hooks



Per 10

Multimag Plus Banner hanger for header

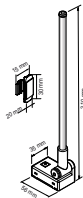

Fits onto and under the shelves or against metal poles and walls. The angle of the tube can be adjusted from 0 to 180°. Reinforced magnet and alu elbow tube with diameter of 10 mm that can hang a banner up to 500 g thanks to adhesive clips. Delivered with two clips.

Aluminium tube.

841 215

White base and straight alu tube - 2 adhesive adapters



Per 10

...did you know?

FOR PROMOTIONAL FRONT SIGNS (not too heavy or too big) opt for the Multimag banner hanger for headers! **FOR DEFINITIVE FRONT SIGNS** opt for the frame header (metal, with hinges). It fits to the top of your fixtures and makes it possible to both conceal the storage areas in the store and insert a communication panel!
Contact us!

R



... how does it work?



MULTIMAG: MULTI-POSITION & MULTI-FUNCTION:

Multimag is a banner hanger developed by Sitour Merchandising to dress up your shelves and animate your sales.

- The Multimag magnetic block allows to set your banners on or under the metal shelves. By easy manipulation of the angle, the magnetic block is rotated 90° and allows the fixation of your banners or posters against the metallic wall.
- The range of Multimag accessories adapts to all metal fixtures in order to present all forms of POS on shelves: Banners, plastic frames, front signs.



Multimag banner hanger, ring hooks

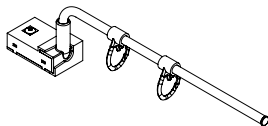

Fits onto and under the shelves or against metal poles and walls. Magnetic base provided with the Multimag angle and elbow tube with an 8 mm diameter. Holds a 500 g poster. Aluminium tube.



841 203	White base and alu tube - 2 ring hooks
723 004	Ring hook

Per 10
Per 50

Multimag banner hanger, open hooks

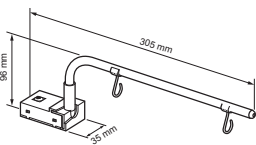

Fits onto and under the shelves or against metal poles and walls. Magnetic base provided with the Multimag angle and elbow tube with an 8 mm diameter. Holds a 500 g poster. Aluminium tube.



841 201	White base and alu tube - 2 open hooks
723 002	Open hook

Per 10
Per 50



Multimag double peg-hook

new

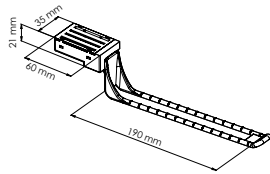

Presents blister-packed light packaging as cross-merchandising. For use under the shelf and against a metal wall or pole. Polyamide glass-fibre reinforced peg-hook (PA6.6) and base composed of a magnetic block and provided with the Multimag angle.



262 013 White - Peg-hook length 200 mm

Per 10

Multimag Shark Foot

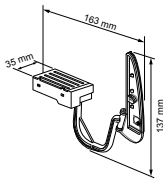

Fits under the shelves or against metal poles and walls. Fastening system on a pivot. Magnetic base with the Multimag angle. Maximum display weight : 300 g or up to a 20 x 20 cm sleeve. PVC tube - Magnet with PP shell.



262 085 White base - Clear shark foot

Per 25

Multimag shelf talker clip

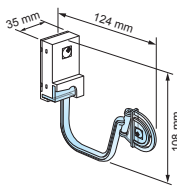

Fits under the shelves or against metal poles and walls. Fastening system on a pivot. Magnetic base with the Multimag angle. Maximum display weight : 200g ABS.



262 841 White base - Clear shelf clips

Per 25

Multimag frame clip

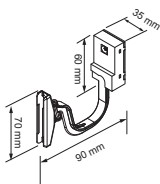

Fits under the shelves or against metal poles and walls. Fastening system on a pivot. Magnetic base with the Multimag angle. Fits with A5 & A6 frames. ABS.



841 207 White base - Clear frame clips

Per 25



... how does it work?

R

ROBUST & ECONOMICAL!

Straight banner hangers allow you to add in-store theatre to your shelves very simply.

Provided with hooks or slots, they adapt to your communication supports. With magnets or adhesive, they adapt to the different supports.



Adhesive split banner holder

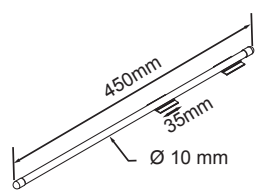

841 609 White - 450Lmm- 10mm diam

Hangs light stapled posters. Ideal for short operations. Fits onto all types of planar surfaces (clean and smooth). Provided with 2 adhesive ceiling hooks and a straight split tube 450mm long and 10mm in diameter. PP + PVC.



Per 10

Magnetic split banner holder

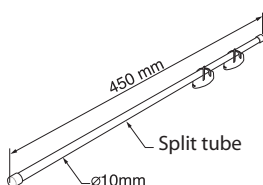

841 605 White - 450Lmm- 10mm diam

723 000 Hook only

Hangs stapled posters. Fits onto metal shelves. Provided with 2 magnetic bases with a magnetic strength of 2 x 4kg and a straight split tube 450mm long and 10mm in diameter. PVC tube - PP ceiling hook.



Per 10

Per 100

Adhesive banner holder with hooks

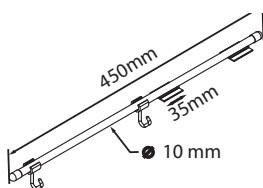

841 610 White - 450Lmm- 10mm diam

Hangs light stapled posters. Ideal for short operations. Fits onto all types of planar surfaces (clean and smooth). Provided with 2 adhesive ceiling hooks and a straight split tube 450mm long and 10mm in diameter and 2 adjustable open hooks. PVC tube - PP ceiling hook - PC hook.



Per 50

Magnetic banner holder with hooks

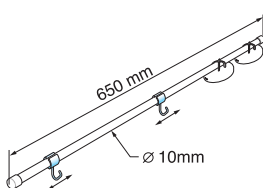

841 613 White - 650Lmm- 10mm diam

Hangs perforated posters. Fits onto metal shelves. Provided with 2 magnetic bases with a magnetic strength of 2 x 8kg, a straight split tube 650mm long and 10mm in diameter and 2 adjustable open hooks. Metal tube - PP shell hook - PC hook.



Per 10

...did you know?



MAXI SHARK, THE BANNER HANGER FOR PROMOTIONAL EVENTS !

A Sitour innovation, the Maxi Shark banner holder is the ideal multifunction support for your promotional operations. Alone, it holds a banner and segmentation on its upper portion. It can support a 20 to 30 cm banner and allows you to create front signage if used by pair. Its ultra-flat base slides under the products



Maxi shark banner holder

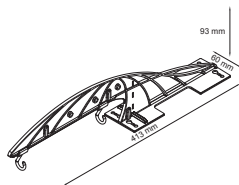

Displays and hangs POS. A front banner can be fixed in the upper portion of the banner holder (delivered with a removable header fin and clear snap fasteners) and a banner can be hung on removable hooks. Base with magnet or suction cups. In PET.



841 707	Clear - base 2 magnetic strips	Per 10
841 709	Clear - base with 2 suction cups	Per 10

THE CUSTOMIZED CROSS-MERCHANDISING

CONSULT US

AT YOUR SERVICE!

Our graphics studio will support you in the design and production of your dressings, POS and communication supports. Banners, front signs, shelf talkers, shelf boosters, segmentation... we are at your service; Contact us!



Spring banner holder for rummage bin

new

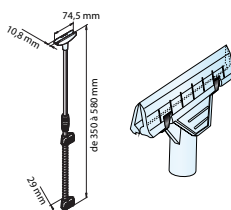

Hangs communication supports on wire bins. Clips separated by a spring making it possible to adapt to the height between the wires. Endcap for frames. The endcap can be replaced with a pinch endcap for sleeves and this communication supports.



821 115	Alu - Spring banner holder PVC with endcap for frames	Per 5
821 111	Clear - Connection pinch endcap	Per 5

... how does it work?

R

The MULTIBASE BANNER HANGER, A SOLUTION FOR EACH GONDOLA BACK!

Sitour patent

Modular:

- Adapts to 5 types of different backs thanks to its 5 fastening lugs
- Very simple lug mounting system (by screwing)

Telescopic:

- Tube length can be adjusted from 500 mm to 900 mm
- Accepts different poster sizes thanks to the sliding hooks on the tube.

Secure:

- The aluminium tube (diameter 12 mm) guarantees the straight position of the banner hanger even in a configuration 900 mm long.
- ABS olive tightening = sustainable locking of the tube at the desired length



Telescopic Multibase banner holder with loading

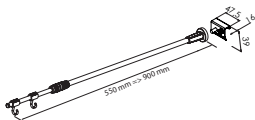

841 511

Grey - Tube + loading tube clip

Hangs perforated communication supports on loading bars. Comprised of a telescopic tube from 550 to 900mm and an attachment loading tube to screw into the tube. Aluminium tube.



Per 10

Telescopic Multibase Banner holder with perforated

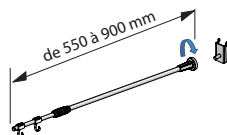

841 521

Grey - Tube + perforated back attachment

Hangs perforated communication supports on a perforated back. Comprised of a telescopic tube from 550 to 900mm and an attachment for perforated gondola back to screw into the tube. Aluminium tube.



Per 10

Telescopic Multibase Banner holder Racks

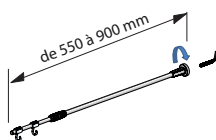

841 515

Grey - Tube + rack attachment

Hangs perforated communication supports on a racks. Comprised of a telescopic tube from 550 to 900mm and an attachment for racks on gondola poles to screw into the tube. Aluminium tube.



Per 10

Telescopic Multibase Banner holder Slatted Bottom

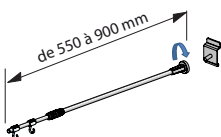

841 517

Grey - Tube + slatted bottom attachment

Hangs perforated communication supports on a slatted back. Comprised of a telescopic tube from 550 to 900mm and an attachment for slatted gondola backs to screw into the tube. Aluminium tube.



Per 10

Magnetic Telescopic Multibase Banner holder

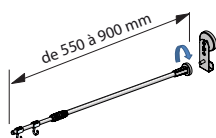

841 513

Grey - Tube + magnet attachment

Hangs perforated communication supports on a loading tube. Comprised of a telescopic tube from 550 to 900mm and a magnet attachment to adhere to any metal surface (screws in the tube). Aluminium tube.



Per 10



... how does it work?

DISPLAY & SUSPEND YOUR COMMUNICATION SUPPORTS!

Floor banner holders are resistant, stable and aesthetic. It makes it possible to suspend large banners, large sleeves and bundle panels. They adapt to all of your sections and as such allow you to safely communicate in any situation!



Magnum T Banner holder

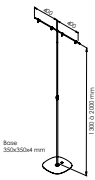

Designed to hang 2 banners (or 1 very large one). Provided with a telescopic tube from 1300 to 2000mm, a tightening olive (between the low tube diameter 16mm and the incoming tube diameter 13mm) securing the chosen height, two 400m perpendicular arms whereon are fixed 4 open hooks and a base of 350X350mm (4mm thick) guaranteeing stability. Painted metal.

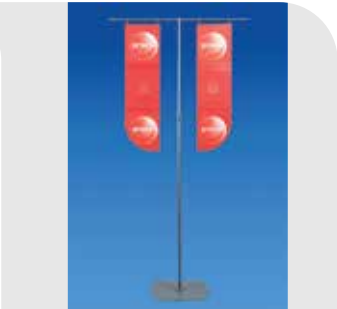

- 774 008** Black - 1300 to 2000 mm
- 774 007** Grey - 1300 to 2000 mm

Per unit
Per unit

Magnum L Banner holder



Designed to hang 1 banner. Provided with a telescopic tube from 1300 to 2000mm, a tightening olive (between the low tube diameter 16mm and the incoming tube diameter 13mm) securing the chosen height, a 400m perpendicular arms whereon are fixed 2 open hooks and a base of 350X350mm (4mm thick) guaranteeing stability. Painted metal.



- 774 010** Black - 1300 to 2000 mm
- 774 009** Grey - 1300 à 2000 mm

Per unit
Per unit

ENHANCE YOUR PROMOTIONS!

CONSULT US

BUNDLE PANEL

Enhance your promotions thanks to bundle panels! Contact us for customised bundles, choice of colour, font, etc.



... how does it work?



COMMUNICATE PERPENDICULAR TO THE SHELF, NEAR THE PRODUCT!

The shelf-talker clip energises your shelves by attaching your small POS perpendicular to the shelf, very close to the product. Clear, the shelf-talker clip is discrete and enhances your message.

Provided with different clips, they adapt to all supports (directly on the shelf, on the label-holder, on the electronic labelling rail, etc.). Ideal for small POS!



Versatile shelf talker clip

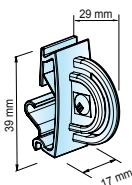

Installs a small-size communication (1 perforation) perpendicular to the shelf on 40 mm the label-holder profiles and main electronic rails in the market.

Comes in an ecodisplay model containing 30% corn starch.



262 741

Clear - Versatile

Per 100

... did you know?



30% CORN STARCH

The ecodisplay shelf clip contains 30% corn starch and 70% polypropylene.

It reduces the use of oil for an environment-friendlier material and the CO² emissions during its incineration.



Eco display versatile shelf talker clip

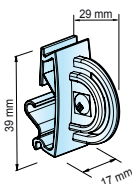

Contains 30% of starch of corn. Guarantees the perfect positioning of your advertising on 40 mm label holder profiles and main electronic rails.



262 739

White - Ecodisplay

Per 100

Paper label-holder shelf talker clip

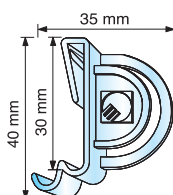

Installs a small-size communication perpendicular to the shelf on a 30 or 40 mm paper label-holder. Injected clip comprised with 1 pin to maintain a small communication (1 perforation). In PP.



262 041

Clear - for paper label-holder

Per 100

Freeline shelf talker clip

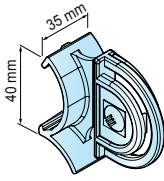

262 701 Clear - for Freeline

Installs a small-size communication perpendicular to the shelf on Freeline profiles. Injected clip comprised of 1 pin maintaining a small communication (1 perforation). In PP.



Per 100

P25 shelf talker clip

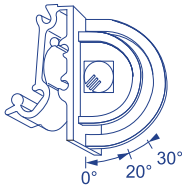

262 641 Clear - for P25 metal shelf front

Installs a small-size communication perpendicular to the shelf on the front C slot of 25 mm shelves. Injected clip comprised of 1 pin maintaining a small communication (1 perforation). In PP.



Per 100

Shelf talker clip for wire and divider

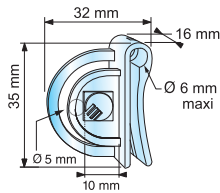

262 047 Clear - for wire and divider

Installs a small-size communication perpendicular to the shelf on the edge of a divider or on a 6 mm wire stop. Injected clip comprised of 1 pin maintaining the communication (1 perforation). In PP.



Per 100

Shelf-talker clip with stop rail

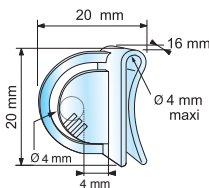

262 401 Clear - for stop rail

Installs a small-size communication perpendicular to the shelf. Injected clip comprised of 1 pin maintaining the communication (1 perforation). In PP.



Per 100

Multimag shelf talker clip

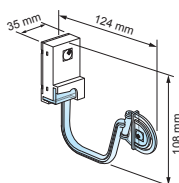

262 841 White Multimag base - Clear shelf talker

Fits under the shelves or against metal poles and walls. Injected clip comprised of 1 pin maintaining the communication (1 perforation). Fastening system on a pivot. Magnetic base with the Multimag angle. Maximum display weight : 200g In PP.



Per 25

... how does it work?



COMMUNICATE PERPENDICULAR TO THE SHELF, NEAR THE PRODUCT!

The Shark foot allows you to fasten communication supports perpendicular to the shelf: shelf-talkers, banners, segmentation.

Its 3-pin fastening system provides a constant maintaining of the communication in straight position. Ideal for medium-sized communication!



Shark foot for Freeline

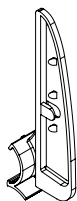

Displays your communications perpendicular to the shelf. Injected clip comprised with 3 pins that maintain the communication. Fits directly on the Freeline labelling profiles making it possible to communicate as close as possible to the products. In PET.



- 262 081** Clear - for Freeline profile
- 262 083** Clear - for Freeline profile - Hinged

Per 100
Per 100

Shark foot for electronic labelling rail

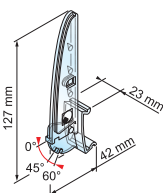

Displays your communications perpendicular to the shelf. Injected clip comprised with 3 pins that maintain the communication. Fits directly on labelling profiles making it possible to communicate as close as possible to the products. In PET.



- 262 059** Clear - for electronic labelling rail

Per 100

Shark foot for paper profile

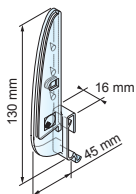

Displays your communications perpendicular to the shelf. Injected clip comprised with 3 pins that maintain the communication. Fits directly on paper labelling profiles making it possible to communicate as close as possible to the products. In PET.

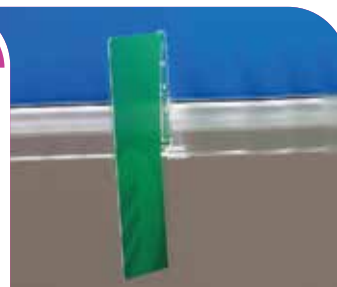

- 262 072** Clear - for ticket strips

Per 100



Shark foot for perforated shelf

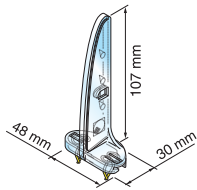

Displays your communications perpendicular to the shelf. Injected clip comprised with 3 pins that maintain the communication. Fits into the perforations on the shelf fronts making it possible to communicate as close as possible to the products. Available in 2 perforation sizes.
In PET.



262 053	Clear - for narrow perforation shelves - 48 mm clearance	Per 100
262 055	Clear - for wide perforation shelves - 75 mm clearance	Per 100

Magnetic plate

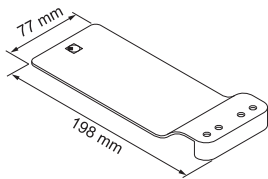

Designed for installing shark feet to adapters 262 055 and 262 053 on non-perforated shelves (and provided with a stop rail from 20 to 40 mm for the version with stop rail). Ideal for cold food area.
Metal.



262 099	White - magnetic lacquer	Per 25
262 097	White - magnetic lacquer with stop rail	Per 25

Shark foot for shelf front

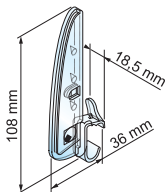

Displays your communications perpendicular to the shelf. Injected clip comprised with 3 pins that maintain the communication. Fits onto the shelf front making it possible to communicate as close as possible to the products.
In PET.



262 051	Clear - for double wire front	Per 100
262 071	Clear - for 25 mm front	Per 100

Pied Shark pour tablette verre (ou Plexi)

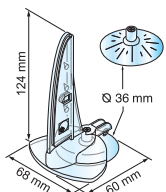

Displays your communications perpendicular to the shelf. Injected clip comprised with 3 pins that maintain the communication. Fits onto the glass shelf front making it possible to communicate as close as possible to the products.
In PET.



262 067	Clear - with suction cup	Per 50
----------------	--------------------------	--------

Shark foot for metal shelf

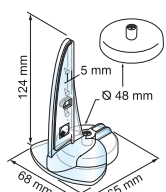

Displays your communications perpendicular to the shelf. Injected clip comprised with 3 pins that maintain the communication. Fits onto the metal shelf front making it possible to communicate as close as possible to the products.
In PET.



262 057	White base with magnet - Clear	Per 25
262 101	Clear - magnetic spatula (black strip)	Per 100

Multimag Shark Foot

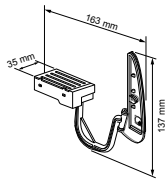

Fits under the shelves or against metal poles and walls. Injected clip with 3 pins to maintain your communication (3 perforations). Fastening system on a pivot. Magnetic base with the Multimag angle. Maximum display weight : 300 g or up to a 20 x 20 cm sleeve. In PET.



262 085

White base - Clear shark foot

Per 25

Shark foot for divider

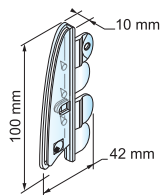

Displays your communications perpendicular to the shelf. Injected clip with 3 pins to maintain your communication (3 perforations). Slides on the front edge of Reverso 60 and 120 mm dividers. In PET.



262 069

Shark foot for divider

Per 100

Shark Foot for shelf divider

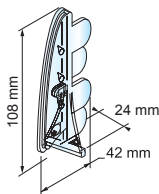

Displays your communications perpendicular to the shelf. Injected clip with 3 pins to maintain your communication (3 perforations). Fits into the divider rail. Allows for the installation of a complete POS segmentation. Compatible with segmentation profiles provided with a divider rail. In PET.



262 079

Shark Foot for shelf divider

Per 100

ENHANCE YOUR OFFER!

CONSULT US

SHOP IN SHOP

Create genuine shop-in shop by affixing a shark foot equipped with a POS segmentation at each end of the rounded segmentation profile. Opt for the Shark foot ref. 262 079 and consult us to create the segmentations!



Shark foot for upright tube

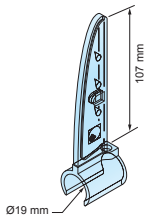

Displays your communications in the textile section perpendicular to the shelf. Injected clip with 3 pins to maintain your communication (3 perforations). Fits directly onto the tube of the uprights (from diameter 8 to 19 mm). Makes it possible as such to communicate perpendicular to the shelf, as close as possible to the products. Associate with the spacer for thinner tubes. In PET.



262 077	Shark foot for textile peg-hook
262 078	Spacer

Per 100
Per 100

Shark Foot for peg-hook

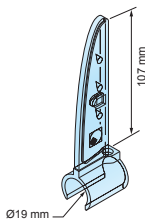

Displays your communications on a peg-hook perpendicular to the shelf. Compatible with wire peg-hooks with a diam. 8 to 12 mm. Includes a shark foot (262 077) and a spacer (262 078). In PET.



262 088	Shark Foot for peg-hook
----------------	-------------------------

Per 100

Perforated sleeve for Shark Foot

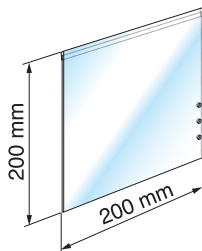

Designed to protect posters fixed to Shark Foot. Provided with 3 perforations. Compatible with the entire Shark foot range. In clear PVC.



241 083	Ht 100 x L 100mm	Per 100
241 087	Ht 100 x L 200 mm	Per 100
241 089	Ht 130 x L 130 mm	Per 100
241 091	Ht 145 x L 160 mm	Per 25
241 075	Ht 200 x L 200 mm	Per 100

... how does it work?



COMMUNICATE AS FACING AROUND THE PRICE!

The shelf booster clip allows to install a sleeve or printed display around the price label. Ideal for indicating a brand, promotion or new item!



Shelf booster clip for electronic labelling rail

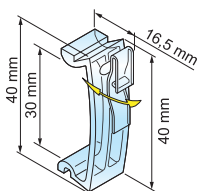

Presents a communication at the front of electronic labelling rails Suitable for all sizes of posters (2 perforations) thanks to the adjustable centre line distance. Injected clip provided with 1 pin maintaining the POS (2 perforations). In PP.

262 543 Clear - for electronic labelling rail



Per 1000

Paper label-holder shelf-booster clip

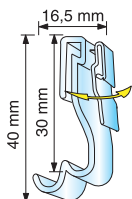

Presents a communication at the front of paper profiles. Suitable for all sizes of posters thanks to the adjustable centre line distance. Suitable for all sizes of posters (2 perforations) thanks to the adjustable centre line distance. Injected clip provided with 1 pin maintaining the POS (2 perforations). In PP.

262 043 Clear - for electronic labelling rail



Per 1000

Freeline shelf-booster clip

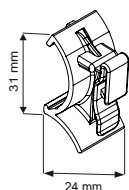

Presents a communication at the front of Freeline. Suitable for all sizes of posters thanks to the adjustable centre line distance. Suitable for all sizes of posters (2 perforations) thanks to the adjustable centre line distance. Injected clip provided with 1 pin maintaining the POS (2 perforations). In PP.

262 703 Clear - for Freeline profile



Per 1000

... did you know?



PROMOTIONAL POS!

For your promotional POS, also discover our range of clips and fasteners in the Add Accessories to your POS chapter!



Shelf-booster

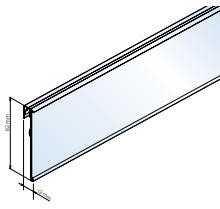

For inserting a POS and communications support as facing. Pinches onto the façade of paper profiles or on the upper portion of electronic labelling rails. Small clear sleeve with pinch. PVC.



642 121	Clear - 82Ht x 180L mm	Per 100
642 120	Clear - 82Ht x 1000L mm	Per 100
642 141	Clear - 97Ht x 180L mm	Per 100
642 140	Clear - 97Ht x 1000L mm	Per 100
642 131	Clear - 107Ht x 180L mm	Per 100
642 130	Clear - 107Ht x 1000L mm	Per 100

... did you know?

R

COMMUNICATE AS FACING & PERPENDICULAR TO THE SHELF!

The shelf booster is provided with an additional rail that allows for the insertion of a «side shelf-talker» and as such communicate perpendicular to the shelf!



Shelf-booster with pinch

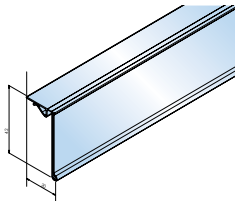

For inserting POS and communications support as facing. Pinches onto the façade of paper profiles or on the upper portion of electronic labelling rails. PVC



641 114 Clear - 39Ht x 1325L mm

Per 100



... how does it work?!



IDEAL FOR YOUR COUPONING OPERATIONS!

The coupon-holder clip allows to fix durably 100 coupons (paper 80 g/m²) on the shelf during your product promotions.



Coupon-holder clip for electronic rail

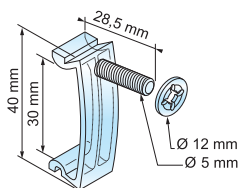

Fits promotional coupons on the shelf as facing. Clips onto the main electronic labelling rails in the market. Injected clip provided with 1 pin maintaining the coupons (2 perforations). In PP.



262 545 Clear - For electronic rail

Per 100

Coupon-holder clip for 30 to 40 mm label-holder

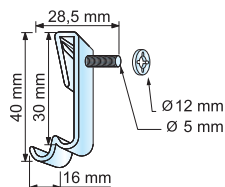

Fits promotional coupons on the shelf as facing. Installs on 30 and 40 mm paper label-holders. Injected clip provided with 1 pin maintaining the coupons (2 perforations). In PP.



262 045 Coupon-holder clip for 30 to 40 mm label-holder

Per 100

Freeline coupon-holder clip

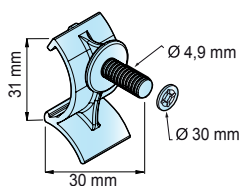

Fits promotional coupons on the shelf as facing. Clips onto Freeline profiles. Injected clip provided with 1 pin maintaining the coupons (2 perforations). In PP.



262 705 Freeline coupon-holder clip

Per 100

Coupon-holder clip P25

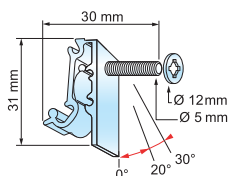

Fits promotional coupons on the shelf as facing. Installs in C slot of 25 mm shelves. Injected clip provided with 1 pin maintaining the coupons (2 perforations). In PP.



262 645 Coupon-holder clip P25

Per 100

... how does it work?!



SELL MORE!

The segmentation profile clarifies and enhances the product offer by segmenting the shelf and informing the customer. The segmentation profile exists without a divider rail or with a divider rail to complete the process of segmenting the shelf



Rounded segmenting rail

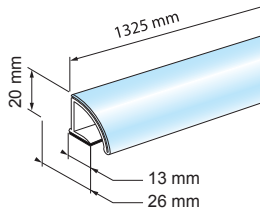

Allows to insert 30 mm high decostrip or label into it. White background. Adhesive or magnetic base. PVC.



123 252	White - Magnetic - Length 1325 mm	Per 10
123 250	White - Magnetic - Length 1245 mm	Per 10
123 257	White - Adhesive - Length 1325 mm	Per 10
123 247	White - Adhesive - Length 1245 mm	Per 10

ENHANCE YOUR OFFER!

CONSULT US

SHOP IN SHOP

Create genuine shop-in-shop by affixing a shark foot equipped with a POS segmentation at each end of the rounded segmentation profile. Opt for the Shark foot ref. 262 079 and consult us to create the segmentations!



Rounded segmentation profile with divider rails

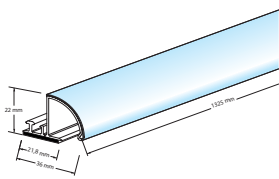

Allows to insert 30 mm high decostrip or label into it. White background. Adhesive or magnetic base. Provided at the rear with a fastening rail for dividers. PVC.



123 241	White - Magnetic - Length 1325 mm	Per 10
123 243	White - Magnetic - Length 1245 mm	Per 10
123 245	White - Adhesive - Length 1325 mm	Per 10

... did you know it?



LOCK YOUR PRESENCE IN ON SHELVES!

To increase the impact of your segmentation, fix segmentation profiles onto printing tray. Your products will be highlighted and your facing product facings fixed.



Straight segmenting rail

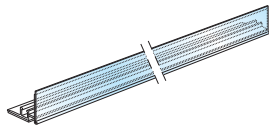

Allows to insert 20 mm high decostrip or label into it. Adhesive base. With a fastening rail for dividers. PVC.



- 123 225** White Base - Adhesive - Length 1245 mm
- 123 223** White Base - Adhesive - Length 1325 mm

Per 25
Per 25

Adhesive angled segmentation rail

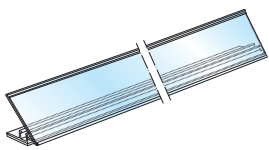

Allows to insert 30 mm high decostrip or label into it. Adhesive base. Provided at the rear with a fastening rail for dividers. In PVC



- 796 109** White Base - Adhesive - Length 1325 mm

Per 10

X'Tract Profile

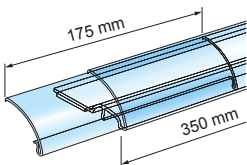

Allows to insert 28 mm high decostrip or label into it. Modular from 400 to 660 mm. Fixed part of 350 mm. Two removable fins of 200 mm. Installs on all shelves with adhesive. PVC.



- 123 242** Clear - Adhesive- Length from 350 to 750 mm

Per 25

Overall promotional support

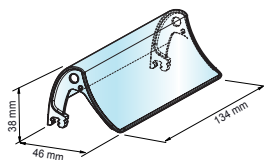

Highlights information on the shelf. Fits onto the fastening rail for dividers. In PET.



- 262 901** Clear - 38Ht x 46width x 134L mm

Per 10



Enhance your communication thanks to the no-glue adhesive that leaves no marks on your glass!

Decorative strip

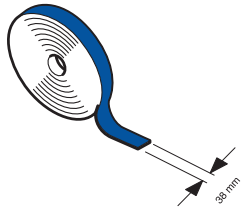

Designed to segment the offer.
 Inserts into the paper labelling profiles with a useful height of 39mm.
 Other colours available on request.
 PVC.



151 099	Blue - 39 mm Ht x100 m Lg	Per unit
151 115	Cherry - 39 mm Ht x100 m Lg	Per unit
151 105	Yellow - 39 mm Ht x100 m Lg	Per unit
151 109	Green - 39 mm Ht x100 m Lg	Per unit
151 107	Orange - 39 mm Ht x 100 m Lg	Per unit

SEGMENT YOUR OFFER!

CONSULT US

Segment your offer using these decorative strips to be inserted into the rounded segmentation profile. Specific colours on demand starting from 4000 linear metres. Contact us!



Decorative strip

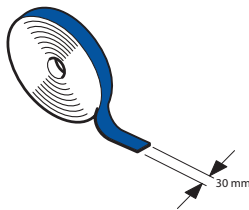

Designed to segment the offer.
 To insert in electronic rails.
 Other colours available on request.
 PVC.



151 199	Blue - 30 mm Ht x 100m Lg	L'unité
151 207	Cherry - 30 mm Ht x 100 m Lg	L'unité
151 205	Yellow - 30 mm Ht x 100 m Lg	L'unité
151 209	Green - 30 mm Ht x 100m Lg	L'unité
151 225	Orange - 30 mm Ht x 100 m Lg	L'unité



R



OPT FOR DIGITAL SOLUTIONS!

Gondola solutions

> Ready-to-install turnkey solutions in your colours



• Video screen fixed to loading tube

We can offer a turnkey solution:

EVIDEO SCREEN
OR TOUCHSCREEN

+

FITTING

+

FINISH

+

INTEGRATION OF
YOUR CONTENT



• Touchscreen fixed to shelf rail



• Video screen on shelf rail

The interactive touchscreen

> An ideal solution for interacting with your shoppers and standing out from the competition



Touchscreen on a base + finish

We can offer a turnkey solution:

IT HARDWARE
+
GRAPHIC CREATION
+
INTEGRATING YOUR CONTENT
+
FINISH
+
INSTALLATION
+
MAINTENANCE



• Interactive touch screen on a base



... can we help you ?

WHICH SIZE TO CHOOSE?

A0 : 841 x 118,9 mm

A1 : 594 x 841 mm

A2 : 420 x 594 mm

A3 : 297 x 420 mm

A4 : 210 x 297 mm

A5 : 148 x 210 mm

A6 : 105 x 148 mm

A7 : 74 x 105 mm

A8 : 52 x 74 mm

01 > Communication holders
• On the shelf



Communication holders

INFORM YOUR CUSTOMERS

Promokits and frame accessories

Displays

Menu card holder, straight

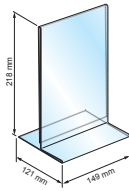

Designed for double-sided communication
Menu card holders made of PET material for a maximum transparency and strength.
In PET.



- 796 229** Size A5
- 796 223** Size A4

Per 10
Per 10

A4 3-sided card holder

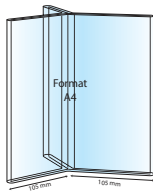

To display 3 A4 posters vertically. Menu card holders made of PET material for a maximum transparency and strength.
PET.



- 796 239** A4 3-sided card holder

Per 10

Angled mini back support

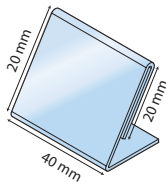

For presenting small cards. Back support made of PET material for a maximum transparency and strength.
PETG.



- 796 243** Size 40 x 20 mm
- 796 241** Size 50 x 40 mm

Per 10
Per 10

Inclined A4 back support + leaflet dispenser

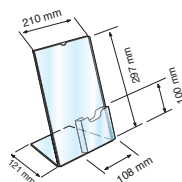

To display a visual and present leaflets.
Crystal PS.



- 796 237** Angled A4 back support + 1/3 of A4 leaflet dispenser

Per 10

PET angled back support

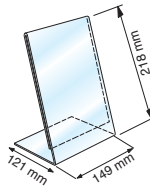

Designed with a rear return that thrusts the sheet against the front side. Back support made of PET material for a maximum transparency and strength. The angle provides excellent visibility for the poster.
In PET.



- 796 227** Size A5
- 796 224** Size A4

Per 10

...did you know?



By favouring PET products, you are contributing to reducing greenhouse gases.
Share our commitment!



PET bevelled Menu card holder

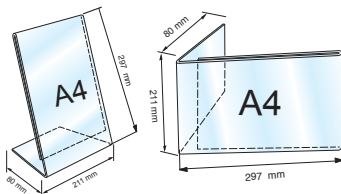

Designed with a rear return that thrusts the sheet against the front side. The bevelled leg allows for use in horizontal or vertical position. Angled for excellent poster visibility. In PET.
PET, thickness 1.5mm.



- 796 231** Size A6
- 796 233** Size A5
- 796 235** Size A4

Per 10
Per 10
Per 10



...did you know?

Enhance your communication thanks to our Premium range of supports! Modern design and perfectly clear (Acrylic)!



Vertical prestige angled back support

new

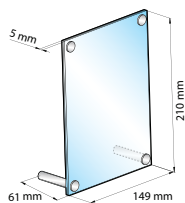

Designed for presenting posters vertically. The metal rods maintain and angle the communication for better visibility. Acrylic. Acrylic, thickness 2.5 mm. H210 x l. 150mm



798 021

Size A5

Per 10

Magnetic straight menu card holder

new

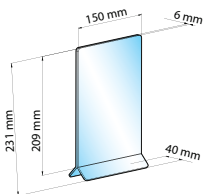

Designed for front/back presentation of communication supports. To be installed. Straight vertical back support. Assembles and perfectly maintains the poster. Acrylic. Acrylic, thickness 3 mm. H210 x l.150 mm Other formats available on demand.



798 029

Size A5

Per 10

Sliding card holder

new

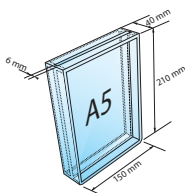

Designed for front/back presentation of small communication supports. To be installed. The sliding system facilitates access to the poster. Acrylic, thickness 3 mm. Other widths available on demand.



798 001

Size A5

Per 15

798 003

Size A4

Per 15

Magnetic card holder

new

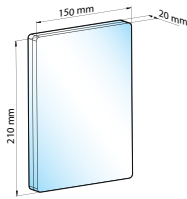

Designed for front/back presentation of small communication supports.
To be installed. The magnets assemble and perfectly maintain the poster in the card holder.
Acrylic.
Acrylic, thickness 10 mm.



798 009 Size A5
798 011 Size A4

Per 10
Per 10

Card holder with screws

new

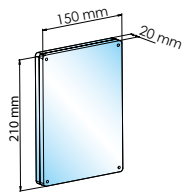

Designed for front/back presentation of small communication supports.
To be installed. The screws assemble and perfectly maintain the poster in the card holder.
Acrylic.
Acrylic, thickness 10 mm.
Other formats available on demand.



798 013 Size A5

Per 10

Card holder with base

new

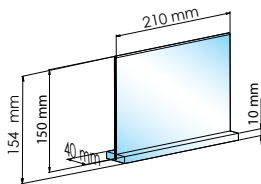

Designed for front/back presentation of small communication supports. To be installed.
Perfectly stable thanks to its 3 mm thick base.
Acrylic, thickness 1.5 mm. Other formats available on demand.
Acrylic.



798 005 Size A5

Per 10



Leaflet dispenser to be installed

new

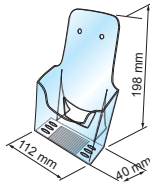

Designed for presentation on a counter or to hung by the perforations located on the back. Available in several formats. Crystal PS.



797 325	Size 1/3 A4	Per 10
797 327	Size A5	Per 20
797 329	Size A4	Per 10

CUSTOMIZED YOUR LEAFLET DISPENSER

CONSULT US

For more impact, customise your leaflet dispensers with your signature! On demand, Contact us.



3-bin leaflet dispenser to be installed

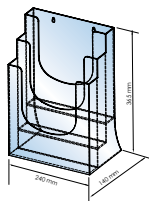

Designed for presentation on a counter or to be hung by the perforations located on the back. They can be customised with your signature, consult us. Other widths available on demand. Crystal PS.



797 319	Size 1/3 A4	Per 25
797 323	Size A5	Per 16
797 321	Size A4	Per 6

Revolving leaflet dispenser

new

Designed to present your leaflets. Comprised of 4 leaflet dispensers on a rotating plateau with plastic ball bearings. Capacity 3.5 cm per box. Crystal PS.



797 350	Size 1/3 A4	Per unit
797 352	Size A5	Per unit

Adhesive 2-position leaflet dispenser

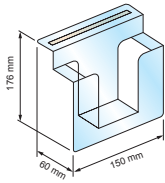

Economical. Attaches with adhesive tape to a horizontal or vertical support. For 1/3 A4 or A6. The side and lower portions can be customised. Delivered flat. Crystal PS.

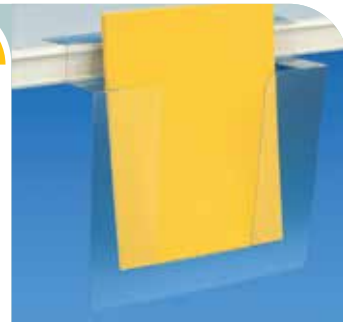

797 341 Adhesive 2-position leaflet dispenser

Per 50

Wall leaflet dispenser

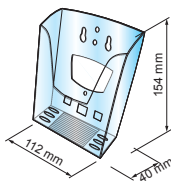

Designed to be hung from the perforations located on the back. Can be presented on a counter thanks to the leg (ref. 797 331). Other widths available on demand. Crystal PS.



797 335 Size 1/3 A4

Per 10

797 337 Size A5

Per 20

797 339 Size A4

Per 10

Wall leaflet dispenser leg

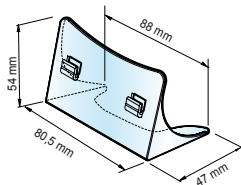

Designed to allow for presenting communications on a counter. Inserts at the rear of the wall leaflet dispenser to stabilise it. Crystal PS.



797 331 Leaflet dispenser leg

Per 10

Card holder

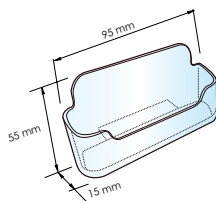

Designed to present your business cards. Available in 2 formats. Crystal PS.



797 299 Size 55 x 95 mm

Per 10

797 298 Size 55 x 100 mm

Per unit

Straight poster holders to be installed

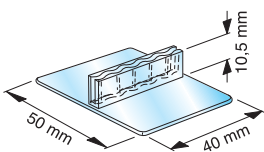

Designed for front/back presentation for your communication support.
Discrete, clear it will blend into the background, highlighting your communication.
Maximum thickness of the poster is 0.5mm.
Crystal PS.

743 007 Clear - To be installed



Per 100

Angled poster holders to be installed

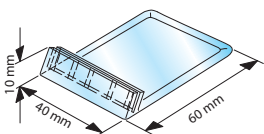

Designed to present your communication supports, angled for better visibility.
Its 60 x 40 mm clear base provides the posters with excellent stability (Th. Max. 0.5mm).
Crystal PS.

743 055 Clear - To be installed



Per 100

...did you know?

Entrust us with creating your communication supports!
Our graphics studio is at your service, contact us!



Base for sleeve and card

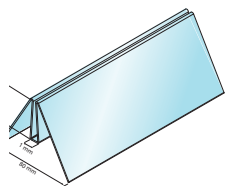

Designed to present sleeves up to 4 mm thick.
Available in 2 formats.
In PETG.

753 009 Length 100 mm

753 011 Length 150 mm



Per 50

Per 50

Support for adhesive straight thick poster

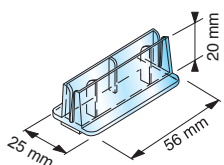

Designed to present posters up to 4 mm thick. With its clear base, it will blend into the background and highlight your poster. The adhesive guarantees that the support will be maintained at the desired location.
In PET.

753 007 Clear - adhesive



Per 100

Antireflection adhesive clear sleeve



Fits onto the walls with adhesive.
Protects posters.
Other widths available on demand.
In PVC antireflection.



241 064	Size A5 horizontal	Per 10
241 062	Size A4 horizontal	Per 10
241 065	Size A3 horizontal	Per 10
241 067	Size A5 vertical	Per 10
241 063	Size A4 vertical	Per 10
241 069	Size A3 vertical	Per 10

...did you know?

We produce sleeves to your size and in your choice of material.
Consult us!

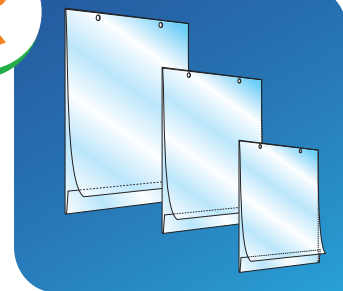

PET adhesive clear sleeve



Fits onto the walls with adhesive.
Protects posters. In PET.
Other formats available on demand.
In PET.



241 509	Size A5 horizontal	Per 10
241 510	Size A4 horizontal	Per 10
241 511	Size A3 horizontal	Per 10
241 529	Size A5 vertical	Per 10
241 530	Size A4 vertical	Per 10
241 531	Size A3 vertical	Per 10



...did you know?

For optimum protection for your posters, opt for thermowelded sleeves!



Thermowelded adhesive sleeve

new

Fits onto the walls with adhesive. Thermowelded, on the sides of the sleeve, your posters are perfectly protected. Can be used outdoors.



241 088	Size A5 horizontal	Per 10
241 086	Size A4 horizontal	Per 10
241 084	Size A3 horizontal	Per 10
241 090	Size A5 vertical	Per 10
241 082	Size A4 vertical	Per 10
241 080	Size A3 vertical	Per 10

Magnetic clear sleeve

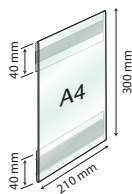

Fits onto metal walls thanks to the magnetic strips. Protects your posters. Other formats available on demand. Crystal PVC.



241 016	Size A5 horizontal	
241 018	Size A4 horizontal	
241 020	Size A3 horizontal	
241 012	Size A5 vertical	Per 10
241 013	Size A4 vertical	Per 10
241 014	Size A3 vertical	Per 10



Aluminium frame to be installed and hung

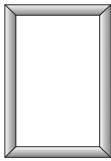

Versatile: Designed to be hung or installed on a counter.
Aluminium profile finish with snapping open/close system. Vertical or horizontal use. In Aluminium.



860 131	Size A6	Per unit
860 129	Size A5	Per unit
860 127	Size A4	Per unit

Alu frame with pinches to be hung A3

new

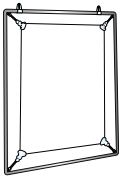

Designed for hanging your communication supports.
Anodized aluminium finish tube In Aluminium.
Comprised of 4 pinches mounted on springs (1 at each angle) to receive your A3 format communication supports.



860 150	Alu frame to be hung A3	Per unit
----------------	-------------------------	----------

Snapping alu frame with rounded angles



Designed for hanging your communication supports.
Aluminium profile finish with snapping open/close system. Other formats available on demand.
In Aluminium.



860 104	Size A4 - 25 mm profile	Per unit
860 108	Size A3 - 25 mm profile	Per unit
860 106	Size A2 - 25 mm profile	Per unit

Snapping alu frame with rectangular angles



Designed for hanging your communication supports.
Aluminium profile finish with snapping open/close system. Other formats available on demand.
In Aluminium.



860 122	Size A5 - 25 mm profile	Per unit
860 120	Size A4 - 25 mm profile	Per unit
860 118	Size A3 - 25 mm profile	Per unit
860 116	Size A2 - 25 mm profile	Per unit

LED spring click frame

new



Designed for hanging your communication supports.
Its LED backlighting draws attention to your posters.
Aluminium profile finish with snapping open/close system. Delivered with mains power supply.
In Aluminium. 2 formats available.



860 140	Size A4	Per unit
860 142	Size A3	Per unit

GIANT PROMOKIT PRINCIPLE

Enhance your communications

> Stable and easy to use



• Promokit

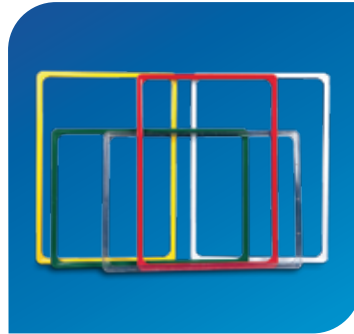

• Plastic poster frame



• Protection sleeve poster frame

Promokit

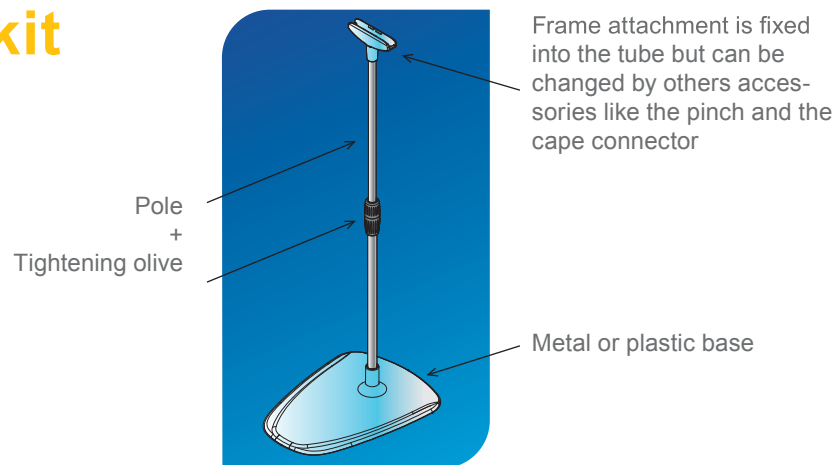

Our advices

	Wire Bin	Cool area	Moist area	Food safety	Promotional area	In the ground
Eco promokit Small 350-580mm	☺	☺	☺	☺	☺	
Eco promokit 600-1000 mm	☺	☺	☺	☺	☺	
Clear base alu Promokit	☺	☺	☺	☺	☺	
Metal base alu Promokit					☺	☺
Magnum Promokit					☺	☺

02 > Promokits and frame accessories
• Promokits



Communication holders

Promokits and frame accessories

Displays

V 131

INFORM YOUR CUSTOMERS

...how does it work?



PROMOKIT:

The perfect solution to communicate efficiently in any situation: in the ground, in wire bin, in a promotional area...To complete with a plastic frame and a protection sleeve.



Eco Promokit

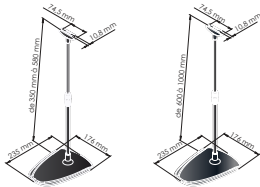

Designed to communicate close to your products. Comprised of a telescopic pole in glass fibres maintained at the desired height by a tightening olive, an attachment for PVC frames and a plastic base. To be associated with a frame and a clear sleeve.



- 821 008** Black - Height 350 - 580 mm
- 821 010** Black - Height 600 - 1000 mm

Per 5
Per 5

Clear base alu Promokit

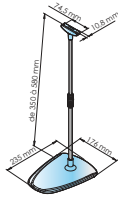

Designed to communicate close to your products. Comprised of a telescopic pole in aluminium maintained at the desired height by a tightening olive, an attachment for PVC frames and a plastic base. To be associated with a frame and a clear sleeve.



- 821 004** Clear/alu - Height 350 - 580 mm

Per 5

Ultra flat metal base alu Promokit



Designed to communicate close to your products. Comprised of a telescopic pole in aluminium maintained at the desired height by a tightening olive, an attachment for PVC frames and an ultra-flat metal base. To be associated with a frame and a clear sleeve.



- 822 006** Alu/metal - Height 600 - 1000 mm

Per 5

Metal base right magnum Promokit



Designed to communicate close to your products. Comprised of a telescopic pole in aluminium maintained at the desired height by a tightening olive, an attachment for PVC frames and a nestable metal base to have more space when storing. To be associated with a frame and a clear sleeve.



- 774 001** Alu/metal - Height 1000 - 1900 mm

Per 5

Promokit Base only

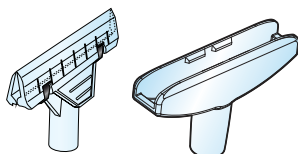

Designed to fit sleeves or thin communication supports (pinch base) or PVC frames (frame base) on the tubes of the Promokits. Nests onto the tube of the Promokit.



- 821 113** Clear - Frame pinch base
- 821 111** Clear - Connector pinch endcap

Per 5
Per 5

A5 Frame

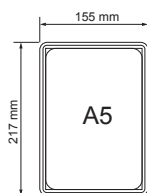

Designed to present an A5 poster (150x 210mm).
Poster to be inserted from the smallest side.
Vertical format. PS.



610 400	A5 Frame White	Per 10
610 401	A5 Frame Yellow	Per 10
610 402	A5 Frame Red	Per 10
610 404	A5 Frame Clear	Per 10

A4 Frame

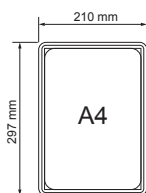

Designed to present an A4 poster (210x 297 mm).
Poster to be inserted from the smallest side.
Vertical format. PS.



610 800	A4 Frame White	Per 10
610 801	A4 Frame Yellow	Per 10
610 802	A4 Frame Red	Per 10
610 803	A4 Frame Green	Per 10
610 804	A4 Frame Clear	Per 10
610 805	A4 Frame Blue	Per 10
610 806	A4 Frame Black	Per 10

A3 Frame

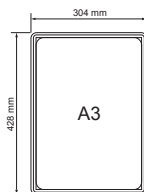

Designed to present an A3 poster (297x 420mm).
Poster to be inserted from the smallest side.
Vertical format. PS.



611 200	A3 Frame White	Per 10
611 201	A3 Frame Yellow	Per 10
611 202	A3 Frame Red	Per 10
611 203	A3 Frame Green	Per 10
611 204	A3 Frame Clear	Per 10
611 206	A3 Frame Black	Per 10

Front/back protection sleeve for frame

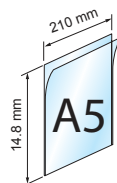

Designed to protect posters. 1-fold sleeve. In PVC antireflection.



744 161	Front/back sleeve for A5 frame	Per 10
744 163	Front/back sleeve for A4 frame	Per 10
744 165	Front/back sleeve for A3 frame	Per 10

new

Spring banner holder for wire bin



To display communication on wire bins.
Thanks to the spring the support can be adjusted according to the wire distance. Frame attachment included. Connector pinch endcap also available.



- 821 115** Alu - PVC endcap for frames
- 821 111** Clear - Connector pinch endcap

Multimag attachment for frame

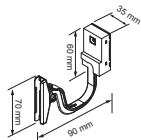

Designed to fit a frame, under or against metal poles and walls. Fastening system on a pivot. Compatible with A5, A4 and A3 frames.
In PC + ABS.



- 841 207** Magnet attachment for frame

Per 25

Magnetic clip

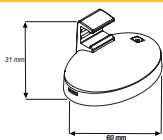

Fits onto a metal wall.
Compatible with plastic A5, A4 and A3 frames.
Magnetic strength 8 kg. PP + magnetic.
In PP.



- 715 045** Wall - vertical 2/ frame recommended
- 715 043** To be installed - horizontal

Per 20
Per 20

Support for magnetic frame

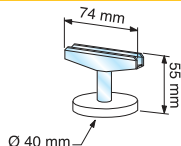

Designed to present a A5, A4 and A3 frame on any metal surface. Magnetic strength 12 kg. PVC crystal + magnetic.



- 772 011** Support for magnetic frame

Per 10

Angled base for frame

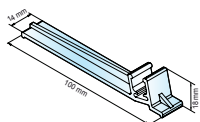

Allows to display A5, A4 and A3 frames easily. Use two bases per frame.
In PC.



- 610 305** Angled base

Per 10

Clear hook for frame

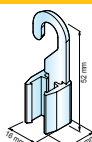

Allows to hang A5, A4 and A3 frame easily. Use to hooks per frame.
In PC



- 610 308** Clear

Set of 10 pairs

Frame pinch

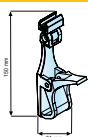

Designed to fit frames. Clear pinch adapted for supports up to 30mm thick comprised of an anti-slide fastening system and an hinged system for fastening the frame.
In PC.



- 610 300** Frame pinch

Per unit



... can we help you ?

THE INTERACTIVE TOUCH SCREEN STATION

... but how does it work ?



THE INTERACTIVE TOUCH SCREEN STATION.

It allows you to:

- Consult the interactive catalogue of products
- Reach the detail of each product
- Receive the product informations by e-mail on your smartphone
- Get intouch directly with the manager or the seller of the store, in real-time or ex-post

As we master it development , our touchscreen solution can easily be adapted to different kind of range of products and needs.

Your project is ours; Contact us!



Catalogue-holder console

new

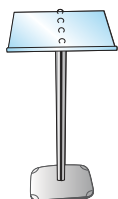

Designed to present your documents front/back on the floor. Console comprised of an anodised alu leg 110 cm high and a clear plexi shelf (32 cm x 47 cm) angled with incorporated rings and a 2 cm front edge. In aluminium and Plexiglass.

630 200

Catalogue-holder console



Per unit

Alu click frame console

new

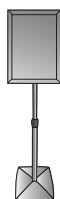

Designed to present your documents front/back on the floor. Anodised alu console comprised of a spring click frame format A4 or A3, which can be adjusted for vertical or horizontal format, and angled from 0° to 90°. Leg height adjusts from 90 to 127 cm. Aluminium.

630 202

Alu click A4 frame console

630 204

Alu click A3 frame console



Per unit

Per unit

Click A3 frame curved console

new

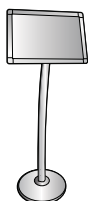

Designed to present your documents front/back on the floor. Design console comprised of a curved leg 120cm high and a rotating alu spring click frame (vertical or horizontal position). Available in lacquered mat epoxy black finish or in anodised alu. In aluminium.

630 206

Black

630 208

Anodised alu



Per unit

Per unit

Black metal console

new

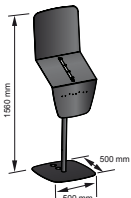

Designed to present your documents front/back on the floor. Metal console 156 cm high composed of rings that can receive A4 format perforated documents and sleeves. Very stable thanks to its wide leg (50 x 50 cm). Black paint finish. Steel.

630 100

Size A4



Per unit

Alu frame totem



Designed to display aluminium frames.
Leg in anodised alu natural Available in 2 heights.
To be used with the connectors to fasten the frames.
Aluminium.



860 181	Totem height 1550 mm	Per unit
860 183	Totem height 1770 mm	Per unit
860 171	Frame connectors	Per unit

...did you know?



Find the complete range of alu spring click frames compatible with alu Totem frames on page 129.



A4 stainless steel Totem pole

new



Displays your communications in A4 format. Totem composed of 2 stainless steel brushed polished poles, 4 sheets to hold A4 format cards and 1 anodised polished aluminium plate. Stainless steel and aluminium.

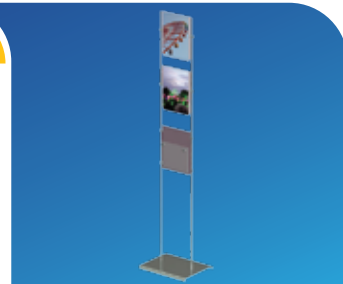

630 212	Totem height 1800mm - 4XA4 Vertical
630 214	Totem height 1800mm - 4XA4 Horizontal

A3 stainless steel Totem pole

new



Displays your communications in A3 format. Totem composed of 2 stainless steel brushed polished poles, 3 sheets to hold A3 format cards and 1 anodised polished aluminium plate. Stainless steel and aluminium.



630 216	Totem height 1800mm - 3XA3 Horizontal
----------------	---------------------------------------

...did you know?



Want to create your own totem configuration? It's possible!
Contact us! Together, we'll create your Totem using our accessories.



Back support pavement attention getter

new

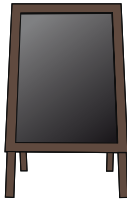

630 226 2 A2 sides

Designed to present a communication. Provided with two slate sides which allows to write your message.
Wood outline - slate



Per unit

Magnetic back support pavement attention getter

new

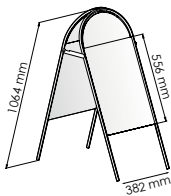

630 240 2 A1 sides

Designed to present your large documents front/back on the floor. Provided with a magnetic clear sleeve system for easy document arrangement.
White lacquered aluminium finish.



Per unit

Back support pavement attention getter

new

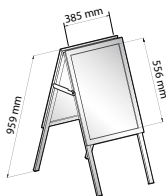

630 236 2 A2 sides

Designed to present your large documents front/back on the floor. Provided with a spring click frame system for easy document insertion.
Anodised aluminium.



Per unit

630 238 2 A1 sides

Per unit



Straight pavement attention getter

new

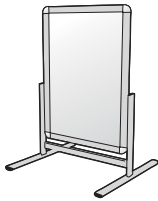

630 242 2 A1 sides

Designed to present your large documents front/back on the floor. Straight pavement attention getter. Provided with a spring click frame system for easy document insertion. Anodised aluminium.



Per unit

Waterproof pavement attention getter

new

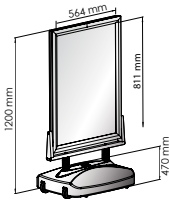

630 246 2 A1 sides

Designed to present your large documents front/back on the floor. Straight pavement attention getter. Water-resistant. Provided with a spring click frame system for easy document insertion. The base is weighted with sand or water. Anodised aluminium. Ideal for outdoor use.



Per unit

Straight pavement attention getter with springs

new

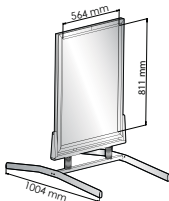

630 244 2 A1 sides

Designed to present your large documents front/back on the floor. Straight pavement attention getter. Provided with a spring click frame system for easy document insertion. Spring system at the base. Anodised aluminium.



Per unit

Reform Display can also be found on facebook

Visit our facebook account



Other dimensions available



Other colors available



New product



Takes part of the **AIR programme** (eco-responsible)

R

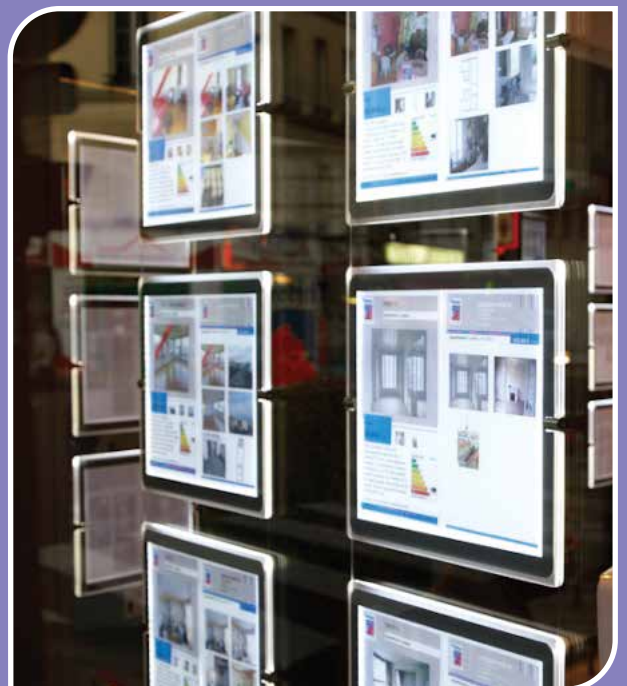

Shopping Baskets



Shopping Basket

SHOPPING BASKETS

Trolley Shopping Basket (2 wheel)

INBOX DIMENSION COLOUR

5
40 LT



Trolley Shopping Basket (4 wheel)

INBOX DIMENSION COLOUR

5
54 LT



Shopping Hand Basket

INBOX DIMENSION COLOUR

10
22 LT



Shopping Hand Basket

INBOX DIMENSION 10
22 LT
COLOUR



Shopping Hand Basket

INBOX DIMENSION 10
28 LT
COLOUR



Shopping Hand Basket

INBOX DIMENSION 10
28 LT
COLOUR



Shopping Hand Basket

INBOX DIMENSION 10
7 LT
COLOUR





Merchandising



Communication



Instore Theater



Adres: Giyim Sanatkarları Sitesi 2. Ada B Blok Kat: 6
No: 608 İkitelli OSB Başakşehir / İSTANBUL

Tel.: +90(212) 659 83 50

Fax: +90(212) 659 83 53

E-mail: info@reformdisplay.com

www.reformdisplay.com